

Made in Germany

# ATEK

ANTRIEBSTECHNIK

Das Winkelgetriebe



Worm gearboxes  
Type: S, SL, Double  
worm gear unit

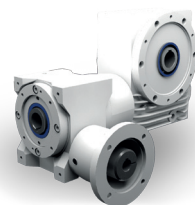
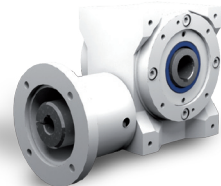
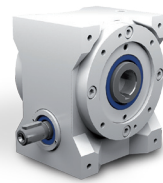

Miniature  
bevel gearboxes

Bevel  
gearboxes

Hygiene-design  
gearboxes

Hybrid  
gearboxes

Worm  
gearboxes

Gearbox  
motors

Servo gearboxes  
(precision gearboxes)

Special  
gearboxes

ATEX  
gearboxes

Gear sets

Service

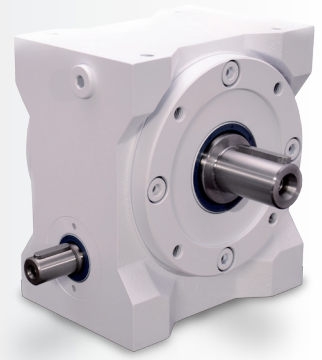

### 9.1 Type overview

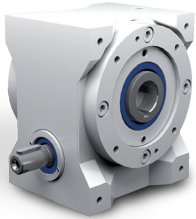

#### Type S – Standard worm gearboxes

Gear ratios:  $i = 05:1$  to  $83:1$   
Maximum output torque: 13720 Nm  
9 sizes, centre-to-centre distance of 040 to 250 mm  
Low-backlash construction < 6 angular minutes possible  
Housing made of grey cast iron

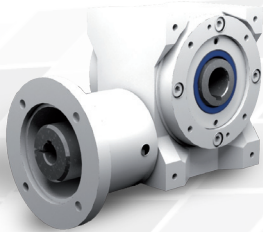

#### Type SL – Type S with flange for motor mounting

Gear ratios:  $i = 05:1$  to  $83:1$   
Maximum output torque: 13720 Nm  
9 sizes, centre-to-centre distance of 040 to 250 mm  
Low-backlash construction < 6 angular minutes possible  
Suitable for fitting IEC standard motors  
Drive side with hollow-bored shaft and flange  
Housing made of grey cast iron

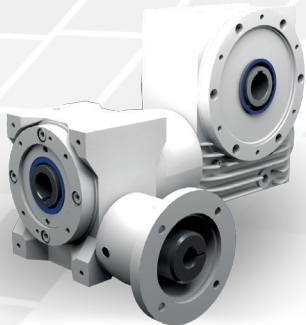

#### Double worm gear unit

Primary gear, available as type S, SL, SLM on SC  
9 standard-size combinations  
For gear ratios up to 6890:1  
Output speeds of 0.1 to 8 rpm

## 9.2 General construction

Due to its mode of operation, a worm gearbox enables high step-down ratios.

In worm gearboxes, both shafts intersect in a defined distance (A). This centre-to-centre distance is reflected in the specification of the gearbox size. (Example: S 100 – centre-to-centre distance 100 mm)

### 9.2.1 Tothing

A gear set consists of worm shaft and worm gear.

The worm shaft made of carburised steel is hardened, the tothing is ground. The worm gear consists of a high-quality bronze alloy, the tothing is milled.

### 9.2.2 Construction types

Due to the modular system, different gearbox construction types can be configured. The variants differ in the type of the shafts, the rotational direction of the shafts, and the support by bearings.

### 9.2.3 Threaded mounting holes

The housing surface on the side 1 and the flange surfaces on the sides 5 and 6 are machined and may be used as mounting surfaces. All flanges always have threaded mounting holes.

You have the following available ordering options:

Gearbox size	Ordering options	Threaded mounting holes are in the housing surfaces on the gearbox side	Threaded mounting holes are in the flanges on the gearbox side
040-250	1	1	5, 6
040-100	2	1, 2	5, 6
040-100	3	1, 3	5, 6
040-100	4	1, 4	5, 6
040-100	5	1, 5	5, 6
040-100	6	1, 6	5, 6
125-250	2	1, 2	5, 6

The standard version has the order code 1.  
Please enquire other mounting options.

Table 9.2.3-1

### 9.2.4 Installation position

The installation position is defined by the gearbox side directed downwards during operation and will be indicated by the associated numeral.

The gearboxes can be used in all installation positions. The technically most favourable and thus recommended installation position is the installation position 1. In this position, the worm shaft is horizontal and located at the bottom.

Please contact us for consultation if the angle of the gearbox side directed downwards deviates more than 15° from the horizontal position. The performance data and torques listed in the selection tables are only valid if the gearboxes are used in the installation positions 1, 5 or 6. The values must be reduced by 10%, if the worm shaft is vertical or located at the top (installation position 3, 4 or 2).

### 9.2.5 Shaft designation – allocation to the gearbox sides

The worm shaft is the fast-rotating shaft. It has the speed  $n_1$  and is identified by  $N_1$ .

The slowly rotating shaft has the speed  $n_2$  and is identified by  $N_2$ . The worm gear is located on this shaft.

The gearbox sides are identified by the numerals 1 to 6. For the allocation of the shafts to the gearbox sides, please refer to the Figure 8.2.5-1 and the Figure 4.3.1-1 Gearbox sides.

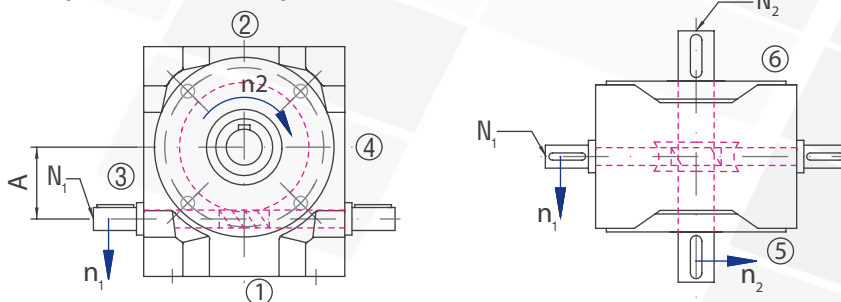

Figure 9.2.5-1

# 9 Worm gearboxes

## 9.2.6 Rotational direction and gear ratio

As standard, the worm gearboxes are delivered with right-handed worm shafts. This results in rotational directions according to Figure 8.2.5-1. In the special design, delivery with left-handed gear teeth is also possible. Please enquire this.

Please refer to the performance tables for the possible gear ratios. Principally, the **actual** gear ratio  $i_{ist}$  must be taken into account for the layout. In some cases, this deviates from the nominal gear ratio  $i$ .

## 9.2.7 Efficiency

The achievable efficiency depends on rotational speed, torque, installation position, sealing, and lubricant type.

### Starting efficiency

The efficiency is always lower during the starting phase and in the cold operating state since the lubricating film is not formed until the sliding motion has started. Therefore a higher torque is needed.

The starting efficiencies listed below are guidance values and valid for run-in gearboxes.

These starting efficiencies must be taken into account for the layout.

Number of threads	Gear ratio range	Starting efficiency	Pitch
1	83 – 62	0.30 – 0.40	3° – 3.5°
1	53 – 30	0.40 – 0.50	5° – 6°
2	26 – 15	0.56 – 0.65	10° – 12°
4	13 – 7.5	0.68 – 0.75	19° – 23°
6	5	0.74 – 0.82	28° – 32°

Table 9.2.7-1

### Operating efficiency

The tooth flanks of worm gearboxes in the as-delivered condition are not yet fully smoothed. Therefore the gearboxes should be run in with approx. 50% of the nominal data, if possible, before they are operated under load.

The efficiencies specified in the performance tables relate to the permissible nominal data and are guidance values for run-in gearboxes with standard sealing that have operating temperature, and an oil viscosity of 460 mm<sup>2</sup>/s.

### Step-up drive

Due to the high efficiency of the ATEK worm gear sets it is possible to drive the gearboxes with 4-thread and 6-thread worm shafts also from the worm gear side and thus to generate a stepping-up.

The efficiency with a driving worm gear is calculated by the formula:  $\eta' = 2 - (1 / \eta)$

### Self-locking

The self-locking is directly related to the efficiency of the gearbox. Please refer to chapter 9.2.11 Self-locking for more information.

## 9.2.8 Lubrication

Different conditions for the lubrication of the toothing and the roller bearings will arise depending on gearbox size, installation position, rotational speed and on-period. In order to ensure these optimally, different oil quantities and viscosities are used.

These will be defined by ATEK based on your ordering details (rotational speed, on-period, and ambient temperature).

They will be reflected in the type designation. You can find the itemisation in the example S 125 10:1 C0 -9.1- 200/A1

/A1 means:

Position	Abbreviation	Explanation	Reference
1	A	Oil viscosity 460	Table 9.2.8-1
2	1	with venting	Table 9.2.8-2

The worm gearboxes are factory-filled with synthetic polyglycol oil and are normally maintenance-free.

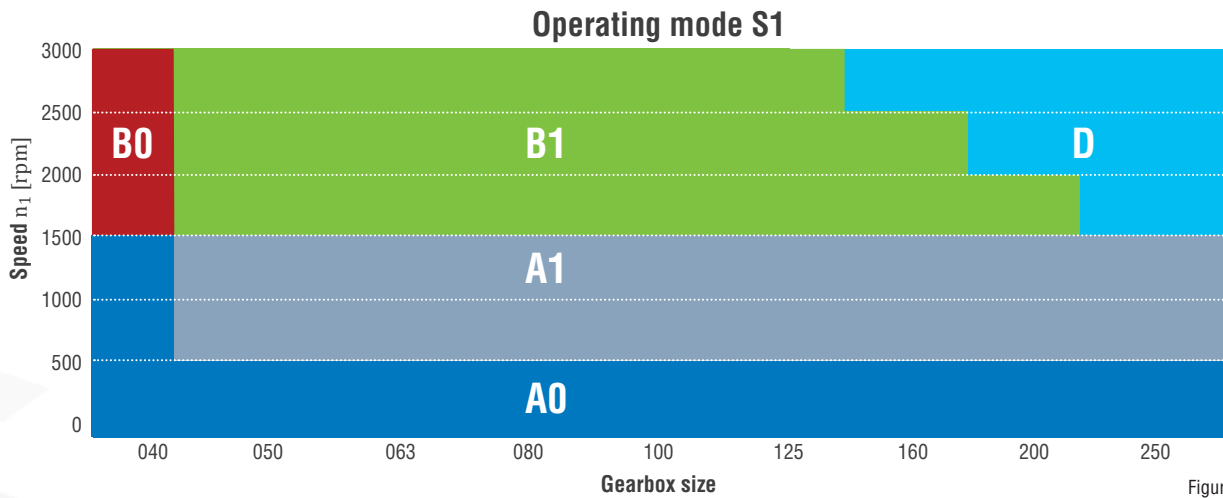

Oil viscosity table

Code; numeral 1	Viscosity
A	460
B	220
C	not available
D	Injection lubrication
F	Fluid grease

In case of very low rotational speeds, lubrication by fluid grease is also possible.

Table 9.2.8-1

At operating temperatures over 50°C, high pressure will develop through air expansion in the gearbox. Then a permanent pressure compensation must be ensured. To this end, the use of a vent filter is prescribed.

Code; numeral 2	Vent filter
0	No
1	Yes

Table 9.2.8-2

### 9.2.9 Vent filter

If venting is required the gearboxes will be delivered with a vent filter. The vent bores will be equipped with screw plugs for transport. The vent filter will be enclosed as a separate item and must be mounted in the intended position prior to commissioning. An elbow may be required. Please adhere to the operating instructions!

The position will be specified in the order documents. Please refer to Figure 8.2.9-1; Installation positions, for the position of the filter. Here, E4, for example, means: Venting on side 4.

Worm gearboxes



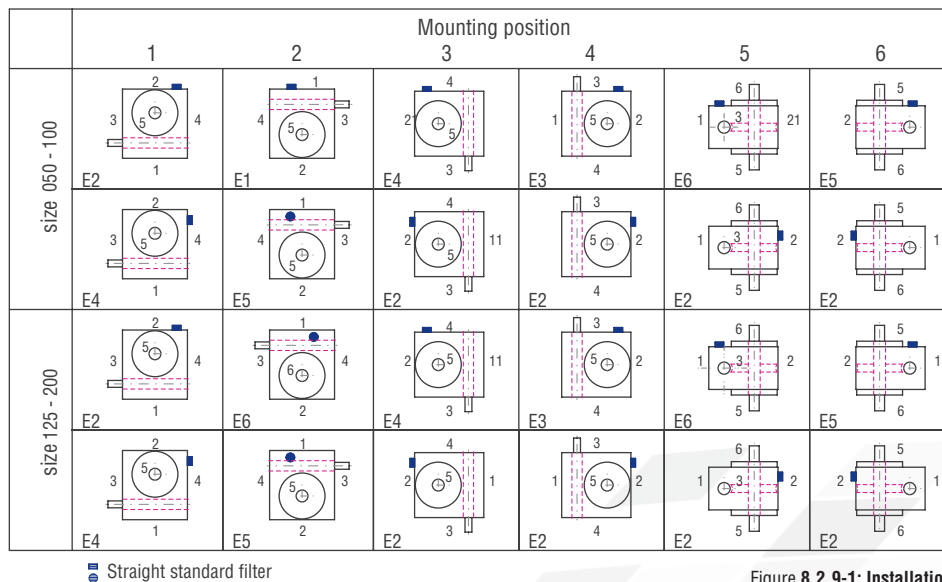

Figure 8.2.9-1; Installation positions

## 9.2.10 Low-backlash construction

For optimal running, the tooth space in the gear set is manufactured larger than the tooth. When the direction of rotation is changed, this results in a rotation angle until the counter-rotating tooth flanks contact each other. This rotation angle is called circumferential backlash.

### Circumferential backlash, measuring method

The circumferential backlash is measured after the drive shaft ( $N_1$ ) has been fixed. A force of around 2% of the nominal torque is applied to the output shaft ( $N_2$ ) in both rotational directions. A tooth backlash will result between the two final positions. This can be measured as rotation angle and is indicated in minutes of arc [arcmin].

### Circumferential backlash, type

All ATEK worm gearboxes can be delivered as low-backlash types. The following values can be set with standard gear sets:

Ordering option	Gear set	040 – 125	160 – 250
/0000	Standard	$\leq 30$ arcmin	$\leq 30$ arcmin
/S2	Standard	$\leq 10$ arcmin	u.r.
/S1	Standard	$\leq 6$ arcmin	u.r.
/S0	Special gear set	$\leq 3-6$ arcmin	u.r.

Table 8.2.10-1

Abbreviation: u.r. – upon request

## 9.2.11 Self-locking

Worm gearboxes are self-locking if the gearboxes cannot be driven from the worm gear side.

The self-locking is directly related to the efficiency of the gearbox. If self-locking is demanded the corresponding efficiency of the gearbox with driving worm must be below 0.5. If a gearbox must be unconditionally self-locking, or alternatively, unconditionally not self-locking, we ask to contact us for consultation, giving a description of the case of application.

### Static self-locking

Worm gearboxes are statically self-locking if starting from standstill with driving worm gear is impossible.

The self-locking depends on the pitch of the toothing. The angle is  $2.5^\circ$  to  $5^\circ$ . Please enquire these.

Vibrations may override / deactivate the self-locking. Therefore a self-locking toothing cannot always take the place of a brake or an anti-reversing device.

## Dynamic self-locking

Worm gearboxes are dynamically self-locking if, with rotating gearbox mechanism, continued operation is impossible due to torque action on the worm gear (output side) of the gearbox. The overrun occurring after switching-off depends on the rotating masses on the drive side. Dynamic self-locking is only possible with very large gear ratios in the range of low driving speeds. Please enquire these.

## Limits

If driven parts have high mass inertia moments no self-locking must occur during the run-down process. Extremely high load peaks may occur in case of sudden blocking of the gearbox. In such cases, a gearbox with multistart worm should be used whenever possible. Also, if a braking motor or a separate brake is used on the drive side, the braking torque must not be too high, and it must be mitigated by using an additional flywheel mass on the drive side

# 9.3 Type S – Standard worm gearboxes

## 9.3.1 Features

Nominal gear ratios:  $i = 05:1$  to  $83:1$   
 Maximum output torque:  $13,720 \text{ Nm}$   
 8 sizes, centre-to-centre distance of  $040$  to  $250 \text{ mm}$   
 Low-backlash construction  $< 6$  angular minutes possible  
 Housing made of grey cast iron

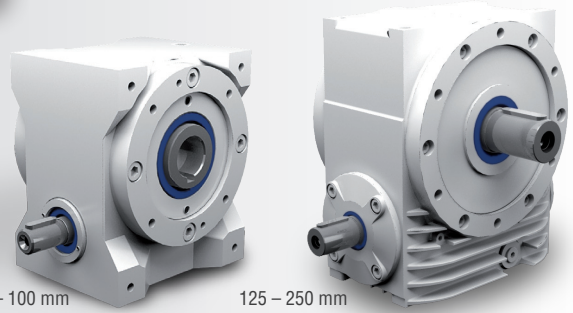

## 9.3.2 Models

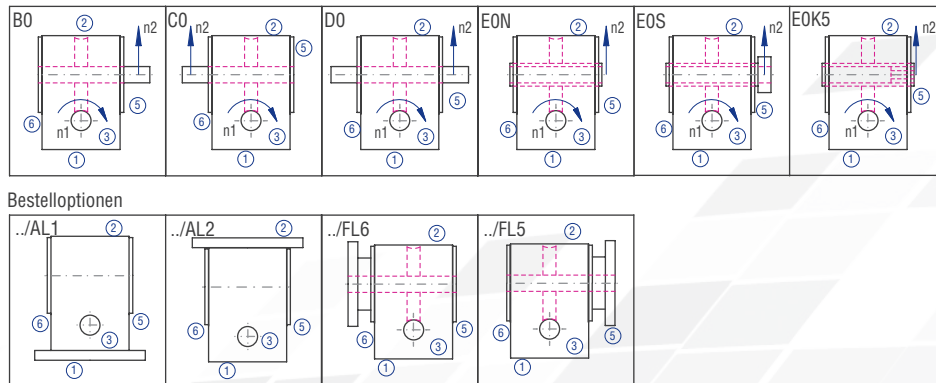

Figure 9.3.2-1; Models

## 9.3.3 Gearbox sides

The example shows the Model B0

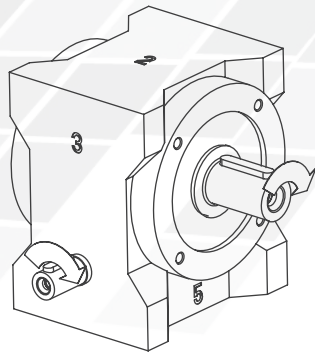

Figure 9.3.3-1; Gearbox sides

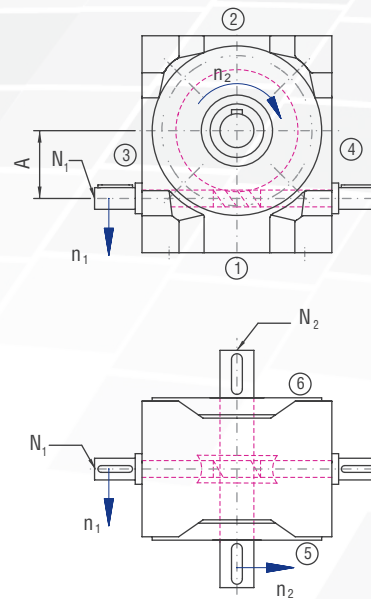

Figure 9.3.3-2; Shaft designations

## 9.3.4 Order code

The order code reflects the customer specifications. Example:

Type	Size	Gear ratio	Model	Fixing side	Installation position	Speed $n_2$	Design
S	063	10:1	B0-	1.	1-	150	/0000
<b>Description</b>	Centre-to-centre distance A; Table 9.3.5-1	Table 9.3.5-1	Figure 9.3.2-1; Models	Gearbox side on which fixing is made Table 9.2.3-1 Figure 4.3.1-1; Gearbox sides	Side directed downwards Figure 4.3.1-1; Gearbox sides	Slowly rotating shaft; Table 9.3.5-1	Standard

Table 9.3.4-1









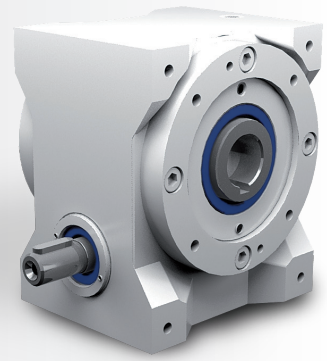

### Characteristics

Characteristic	Standard	Option
<b>Toothing</b>	Hardened and ground worm shaft / bronze worm gear	See chapter 9.2.1
<b>Gear ratio</b>	5:1 to 83:1	
<b>Housing / Flanges</b>	Grey cast iron	
<b>Threaded mounting hole</b>	On gearbox side 1 and on the flanges	See chapter 9.2.3
<b>Shaft</b>	Material 1 C45, shaft ends greased Fit with ISO j6 tolerance with parallel keyway: according to DIN 6885 Sheet 1	See chapter 4.6.2
<b>Hollow shaft</b>	Material 1 C45, shafts greased Fit with ISO H7 tolerance with parallel keyway: according to DIN 6885 Sheet 1	See chapter 4.6.3
<b>Radial shaft seal ring</b>	NBR, form A	See chapter 4.8
<b>Ambient temperature</b>	-10°C to +90°C. The values of the performance tables are valid for 20°C	See chapter 4.9.3
<b>Circumferential backlash</b>	< 30 arcmin	See chapter 9.2.10
<b>Protection class</b>	IP 54	See chapter 4.5
<b>Corrosion protection</b>	Prime coat; layer thickness > 40 µm	See chapter 4.4
<b>Bearing life L10h</b>	more than 15,000h	See chapter 4.9.1
<b>Oil change intervals</b>	Not required if the oil temperature is kept < 90°C The lifetime of the bearings can be increased by the factor 1.5 if the oil is changed after the first 500 service hours and then every 5000 service hours.	See chapter 9.2.8
<b>Lubricant</b>	Synthetic lubricants	See chapter 9.2.8

## Performance data

i	i ist		n <sub>1</sub> [rpm]					
			3000	1500	1000	750	500	150
5:1	29:6	n <sub>2</sub> [rpm]	600.0	300.0	200.0	150.0	100.0	30.0
		P <sub>1N</sub> [kW]	2.26	1.43	1.09	0.87	0.64	0.25
		T <sub>2N</sub> [Nm]	33	41	47	49	53	67
		P <sub>1NT</sub> [kW]	1.85	1.25	1.10	0.90	0.80	0.00
		Efficiency	0.94	0.94	0.93	0.87	0.90	0.86
7.5:1	29:4	n <sub>2</sub> [rpm]	400.0	200.0	133.0	100.0	66.0	20.0
		P <sub>1N</sub> [kW]	1.68	1.06	0.81	0.65	0.48	0.19
		T <sub>2N</sub> [Nm]	36	45	51	54	58	73
		P <sub>1NT</sub> [kW]	1.45	0.95	0.77	0.70	0.61	0.00
		Efficiency	0.92	0.91	0.90	0.89	0.87	0.82
10:1	39:4	n <sub>2</sub> [rpm]	300.0	150.0	100.0	75.0	50.0	15.0
		P <sub>1N</sub> [kW]	1.39	0.77	0.55	0.43	0.32	0.13
		T <sub>2N</sub> [Nm]	39	43	45	47	50	64
		P <sub>1NT</sub> [kW]	1.28	0.83	0.69	0.63	0.87	0.00
		Efficiency	0.91	0.90	0.88	0.87	0.85	0.81
13:1	52:4	n <sub>2</sub> [rpm]	230.0	115.0	76.0	57.0	38.0	11.0
		P <sub>1N</sub> [kW]	0.85	0.45	0.32	0.26	0.19	0.08
		T <sub>2N</sub> [Nm]	31	32	34	36	39	50
		P <sub>1NT</sub> [kW]	1.13	0.75	0.63	0.57	0.52	0.00
		Efficiency	0.88	0.87	0.85	0.84	0.83	0.80
15:1	29:2	n <sub>2</sub> [rpm]	200.0	100.0	66.0	50.0	33.0	10.0
		P <sub>1N</sub> [kW]	0.93	0.60	0.48	0.39	0.29	0.12
		T <sub>2N</sub> [Nm]	37	48	55	58	63	79
		P <sub>1NT</sub> [kW]	0.85	0.55	0.46	0.41	0.36	0.00
		Efficiency	0.86	0.84	0.82	0.81	0.78	0.72
20:1	39:2	n <sub>2</sub> [rpm]	150.0	75.0	50.0	37.0	25.0	7.5
		P <sub>1N</sub> [kW]	0.82	0.49	0.36	0.28	0.21	0.09
		T <sub>2N</sub> [Nm]	43	50	53	55	58	75
		P <sub>1NT</sub> [kW]	0.77	0.49	0.42	0.38	0.34	0.00
		Efficiency	0.84	0.82	0.80	0.78	0.76	0.71

i	i ist		n <sub>1</sub> [rpm]					
			3000	1500	1000	750	500	150
26:1	52:2	n <sub>2</sub> [rpm]	115.0	57.0	38.0	28.0	19.0	5.8
		P <sub>1N</sub> [kW]	0.55	0.30	0.21	0.17	0.12	0.05
		T <sub>2N</sub> [Nm]	36	38	40	42	45	59
		P <sub>1NT</sub> [kW]	0.68	0.44	0.38	0.34	0.31	0.00
		Efficiency	0.80	0.78	0.76	0.75	0.73	0.69
30:1	29:1	n <sub>2</sub> [rpm]	100.0	50.0	33.0	25.0	16.0	5.0
		P <sub>1N</sub> [kW]	0.53	0.37	0.29	0.24	0.18	0.08
		T <sub>2N</sub> [Nm]	36	50	57	60	65	82
		P <sub>1NT</sub> [kW]	0.51	0.33	0.28	0.26	0.23	0.00
		Efficiency	0.75	0.73	0.70	0.68	0.64	0.57
40:1	39:1	n <sub>2</sub> [rpm]	75.0	37.0	25.0	18.0	12.0	3.8
		P <sub>1N</sub> [kW]	0.48	0.32	0.25	0.20	0.15	0.07
		T <sub>2N</sub> [Nm]	44	56	63	66	71	91
		P <sub>1NT</sub> [kW]	0.46	0.30	0.25	0.23	0.21	0.00
		Efficiency	0.72	0.70	0.67	0.65	0.62	0.56
53:1	52:1	n <sub>2</sub> [rpm]	57.0	28.0	18.0	14.0	9.4	2.8
		P <sub>1N</sub> [kW]	0.39	0.21	0.15	0.13	0.09	0.04
		T <sub>2N</sub> [Nm]	44	46	48	51	55	72
		P <sub>1NT</sub> [kW]	0.42	0.28	0.24	0.22	0.20	0.00
		Efficiency	0.68	0.65	0.63	0.61	0.59	0.55
62:1	63:1	n <sub>2</sub> [rpm]	48.0	24.0	16.0	12.0	8.1	2.4
		P <sub>1N</sub> [kW]	0.36	0.20	0.15	0.12	0.09	0.03
		T <sub>2N</sub> [Nm]	45	48	51	53	56	57
		P <sub>1NT</sub> [kW]	0.35	0.23	0.20	0.18	0.16	0.00
		Efficiency	0.63	0.59	0.56	0.54	0.51	0.45
83:1	82:1	n <sub>2</sub> [rpm]	36.0	18.0	12.0	9.0	6.0	1.8
		P <sub>1N</sub> [kW]	0.25	0.14	0.10	0.08	0.05	0.02
		T <sub>2N</sub> [Nm]	36	37	38	38	38	38
		P <sub>1NT</sub> [kW]	0.32	0.21	0.18	0.17	0.15	0.00
		Efficiency	0.56	0.52	0.50	0.48	0.46	0.42

	5:1	7.5:1	10:1	13:1	15:1	20:1	26:1	30:1	40:1	53:1	62:1	83:1
T <sub>2max</sub> [Nm]	73	83	77	59	97	90	77	107	99	87	72	64

## Permissible radial force F<sub>r1</sub> and axial force F<sub>a1</sub> on shaft N<sub>1</sub>

n <sub>1</sub> [rpm]	3000		1500		1000		750		500		150	
T <sub>1</sub> [Nm]	F <sub>r</sub> [N]	F <sub>a</sub> [N]	F <sub>r</sub> [N]	F <sub>a</sub> [N]	F <sub>r</sub> [N]	F <sub>a</sub> [N]	F <sub>r</sub> [N]	F <sub>a</sub> [N]	F <sub>r</sub> [N]	F <sub>a</sub> [N]	F <sub>r</sub> [N]	F <sub>a</sub> [N]
< 10	250	125	310	155	350	175	400	200	450	225	550	275

## Permissible radial force F<sub>r2</sub> and axial force F<sub>a2</sub> on shaft N<sub>2</sub>

n <sub>2</sub> [rpm]	200		125		75		50		30		10	
T <sub>2</sub> [Nm]	F <sub>r</sub> [N]	F <sub>a</sub> [N]	F <sub>r</sub> [N]	F <sub>a</sub> [N]	F <sub>r</sub> [N]	F <sub>a</sub> [N]	F <sub>r</sub> [N]	F <sub>a</sub> [N]	F <sub>r</sub> [N]	F <sub>a</sub> [N]	F <sub>r</sub> [N]	F <sub>a</sub> [N]
< 80	970	485	1250	625	1380	690	1600	800	1800	900	2500	1250

## Inertia moments/mass

Inertia moment J<sub>1</sub> related to the fast-rotating shaft (N<sub>1</sub>)

	Inertia moment [kgcm <sup>2</sup> ]											
	5:1	7.5:1	10:1	13:1	15:1	20:1	26:1	30:1	40:1	53:1	62:1	83:1
J <sub>1</sub>	0.33	0.25	0.18	0.15	0.19	0.15	0.13	0.18	0.14	0.12	0.13	0.12

The mass of the gearbox may deviate depending on the gear ratio and the type.

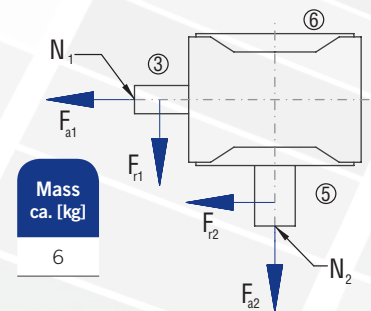

Worm  
gearboxes



## 9.3.6 Type S 040 – Standard worm gearboxes

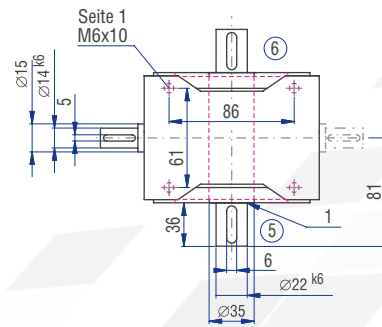
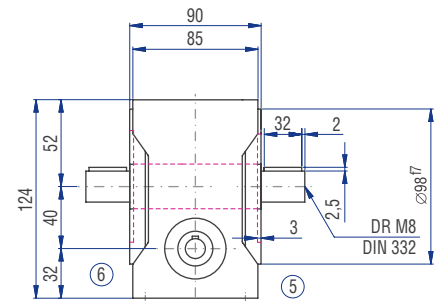
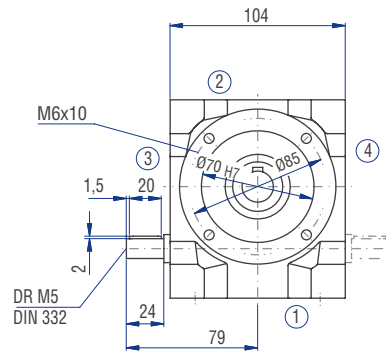
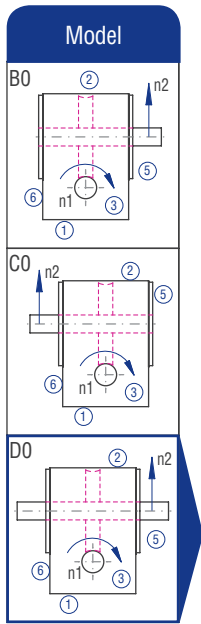

### Implementation VV

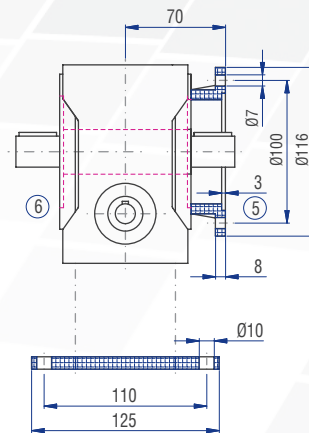
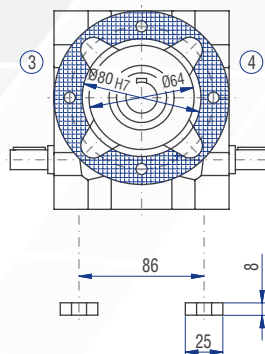
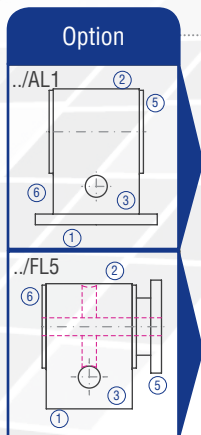
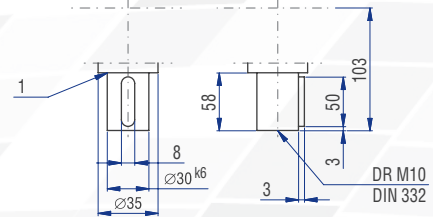

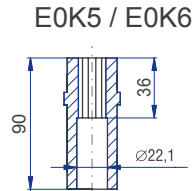
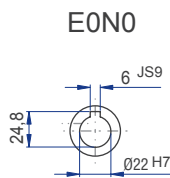
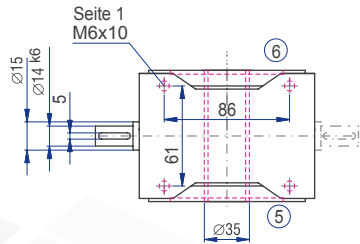
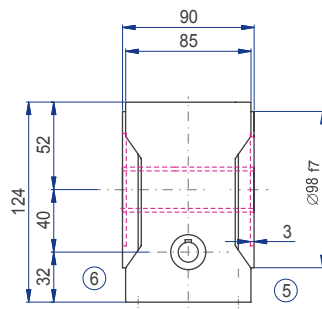
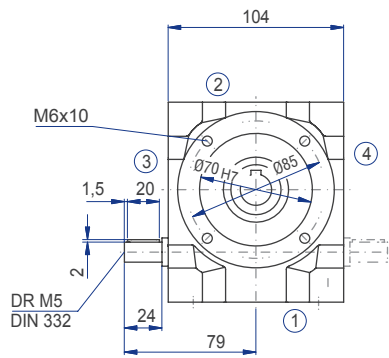

A 6x18x22  
ISO 14

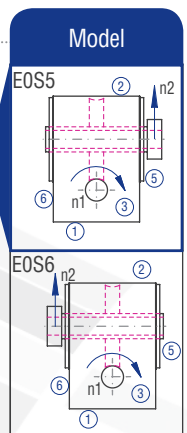
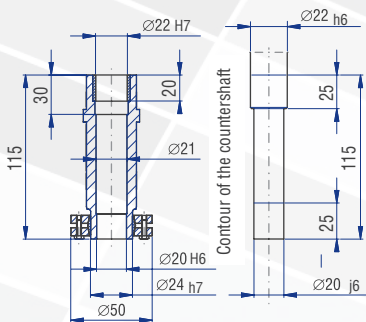
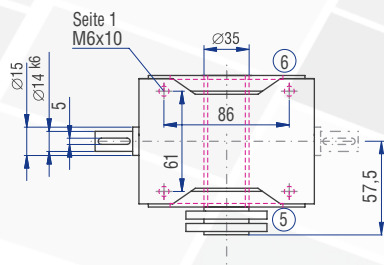
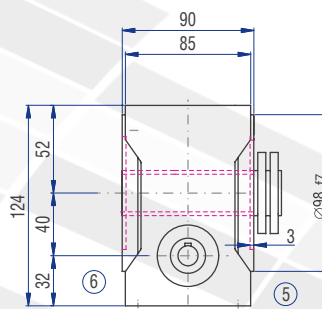
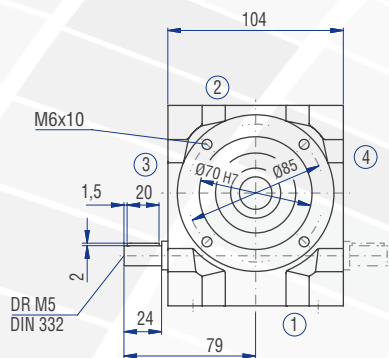
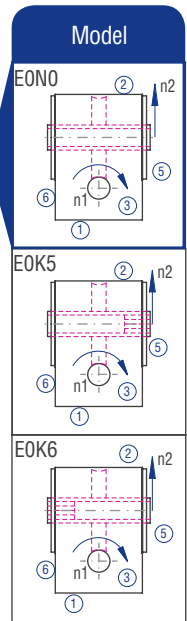

Worm  
gearboxes

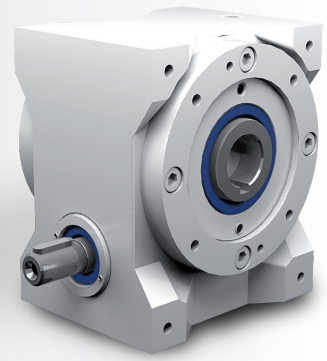

### Characteristics

Characteristic	Standard	Option
<b>Toothing</b>	Hardened and ground worm shaft / bronze worm gear	See chapter 9.2.1
<b>Gear ratio</b>	5:1 to 83:1	
<b>Housing / Flanges</b>	Grey cast iron	
<b>Threaded mounting hole</b>	On gearbox side 1 and on the flanges	See chapter 9.2.3
<b>Shaft</b>	Material 1 C45, shaft ends greased Fit with ISO j6 tolerance with parallel keyway: according to DIN 6885 Sheet 1	See chapter 4.6.2
<b>Hollow shaft</b>	Material 1 C45, shafts greased Fit with ISO H7 tolerance with parallel keyway: according to DIN 6885 Sheet 1	See chapter 4.6.3
<b>Radial shaft seal ring</b>	NBR, form A	See chapter 4.8
<b>Ambient temperature</b>	-10°C to +90°C. The values of the performance tables are valid for 20°C	See chapter 4.9.3
<b>Circumferential backlash</b>	< 30 arcmin	See chapter 9.2.10
<b>Protection class</b>	IP 54	See chapter 4.5
<b>Corrosion protection</b>	Prime coat; layer thickness > 40 µm	See chapter 4.4
<b>Bearing life L10h</b>	more than 15,000h	See chapter 4.9.1
<b>Oil change intervals</b>	Not required if the oil temperature is kept < 90°C The lifetime of the bearings can be increased by the factor 1.5 if the oil is changed after the first 500 service hours and then every 5000 service hours.	See chapter 9.2.8
<b>Lubricant</b>	Synthetic lubricants	See chapter 9.2.8

## Performance data

i	i ist		n <sub>1</sub> [rpm]					
			3000	1500	1000	750	500	150
5:1	29:6	n <sub>2</sub> [rpm]	600.0	300.0	200.0	150.0	100.0	30.0
		P <sub>1N</sub> [kW]	4.74	3.29	2.54	2.08	1.47	0.54
		T <sub>2N</sub> [Nm]	70	96	110	119	125	145
		P <sub>1NT</sub> [kW]	3.90	2.76	2.10	2.04	1.76	0.00
		Efficiency	0.96	0.95	0.94	0.93	0.92	0.88
7.5:1	29:4	n <sub>2</sub> [rpm]	400.0	200.0	133.0	100.0	66.0	20.0
		P <sub>1N</sub> [kW]	3.41	2.42	1.84	1.43	1.01	0.40
		T <sub>2N</sub> [Nm]	74	104	117	120	125	153
		P <sub>1NT</sub> [kW]	3.16	2.12	1.76	1.57	1.36	0.00
		Efficiency	0.94	0.93	0.92	0.91	0.89	0.83
10:1	38:4	n <sub>2</sub> [rpm]	300.0	150.0	100.0	75.0	50.0	15.0
		P <sub>1N</sub> [kW]	3.02	1.64	1.15	0.96	0.71	0.26
		T <sub>2N</sub> [Nm]	85	91	94	103	112	130
		P <sub>1NT</sub> [kW]	2.82	1.88	1.56	1.40	1.23	0.00
		Efficiency	0.93	0.92	0.90	0.89	0.87	0.82
13:1	51:4	n <sub>2</sub> [rpm]	230.0	115.0	76.0	57.0	38.0	11.0
		P <sub>1N</sub> [kW]	1.51	0.82	0.58	0.45	0.32	0.12
		T <sub>2N</sub> [Nm]	55	59	62	64	66	75
		P <sub>1NT</sub> [kW]	2.51	1.67	1.14	1.27	1.13	0.00
		Efficiency	0.90	0.89	0.88	0.87	0.85	0.80
15:1	29:2	n <sub>2</sub> [rpm]	200.0	100.0	66.0	50.0	33.0	10.0
		P <sub>1N</sub> [kW]	1.82	1.32	1.02	0.84	0.65	0.26
		T <sub>2N</sub> [Nm]	74	106	120	131	145	179
		P <sub>1NT</sub> [kW]	1.91	1.27	1.05	0.94	0.82	0.00
		Efficiency	0.88	0.87	0.85	0.84	0.81	0.74
20:1	38:2	n <sub>2</sub> [rpm]	150.0	75.0	50.0	37.0	25.0	7.5
		P <sub>1N</sub> [kW]	1.54	1.03	0.73	0.63	0.47	0.18
		T <sub>2N</sub> [Nm]	81	106	110	123	133	158
		P <sub>1NT</sub> [kW]	1.70	1.12	0.93	0.84	0.74	0.00
		Efficiency	0.87	0.85	0.83	0.81	0.78	0.72

i	i ist		n <sub>1</sub> [rpm]					
			3000	1500	1000	750	500	150
26:1	51:2	n <sub>2</sub> [rpm]	115.0	57.0	38.0	28.0	19.0	5.8
		P <sub>1N</sub> [kW]	1.04	0.58	0.42	0.32	0.24	0.09
		T <sub>2N</sub> [Nm]	71	76	80	82	86	98
		P <sub>1NT</sub> [kW]	1.51	1.00	0.84	0.76	0.68	0.00
		Efficiency	0.84	0.81	0.79	0.78	0.75	0.70
30:1	29:1	n <sub>2</sub> [rpm]	100.0	50.0	33.0	25.0	16.0	5.0
		P <sub>1N</sub> [kW]	1.12	0.79	0.59	0.54	0.42	0.18
		T <sub>2N</sub> [Nm]	82	113	121	144	157	201
		P <sub>1NT</sub> [kW]	1.14	0.76	0.63	0.06	0.50	0.00
		Efficiency	0.79	0.77	0.74	0.72	0.68	0.59
40:1	38:1	n <sub>2</sub> [rpm]	75.0	37.0	25.0	18.0	12.0	3.8
		P <sub>1N</sub> [kW]	0.87	0.65	0.52	0.41	0.31	0.13
		T <sub>2N</sub> [Nm]	80	118	134	137	147	183
		P <sub>1NT</sub> [kW]	1.02	0.68	0.57	0.52	0.46	0.00
		Efficiency	0.76	0.75	0.71	0.69	0.65	0.57
53:1	51:1	n <sub>2</sub> [rpm]	57.0	28.0	18.0	14.0	9.4	2.8
		P <sub>1N</sub> [kW]	0.65	0.38	0.27	0.22	0.16	0.06
		T <sub>2N</sub> [Nm]	77	85	88	91	95	110
		P <sub>1NT</sub> [kW]	0.92	0.62	0.52	0.48	0.43	0.00
		Efficiency	0.73	0.69	0.67	0.64	0.61	0.55
62:1	62:1	n <sub>2</sub> [rpm]	48.0	24.0	16.0	12.0	8.1	2.4
		P <sub>1N</sub> [kW]	0.61	0.42	0.31	0.25	0.18	0.06
		T <sub>2N</sub> [Nm]	81	105	109	112	113	113
		P <sub>1NT</sub> [kW]	0.75	0.50	0.43	0.39	0.36	0.00
		Efficiency	0.67	0.64	0.60	0.57	0.53	0.45
83:1	83:1	n <sub>2</sub> [rpm]	36.0	18.0	12.0	9.0	6.0	1.8
		P <sub>1N</sub> [kW]	0.39	0.21	0.15	0.12	0.09	0.03
		T <sub>2N</sub> [Nm]	59	63	64	66	69	75
		P <sub>1NT</sub> [kW]	0.70	0.47	0.41	0.37	0.34	0.00
		Efficiency	0.58	0.56	0.54	0.52	0.49	0.44

	5:1	7.5:1	10:1	13:1	15:1	20:1	26:1	30:1	40:1	53:1	62:1	83:1
T <sub>2max</sub> [Nm]	150	167	152	100	195	179	137	219	197	145	120	112

## Permissible radial force F<sub>r1</sub> and axial force F<sub>a1</sub> on shaft N<sub>1</sub>

n <sub>1</sub> [rpm]	3000		1500		1000		750		500		150		
	T <sub>1</sub> [Nm]	F <sub>r</sub> [N]	F <sub>a</sub> [N]	F <sub>r</sub> [N]	F <sub>a</sub> [N]	F <sub>r</sub> [N]	F <sub>a</sub> [N]	F <sub>r</sub> [N]	F <sub>a</sub> [N]	F <sub>r</sub> [N]	F <sub>a</sub> [N]	F <sub>r</sub> [N]	F <sub>a</sub> [N]
< 15		590	295	730	365	820	410	940	470	1050	525	1300	650
> 15		450	225	560	280	630	315	720	360	810	405	1000	500

## Permissible radial force F<sub>r2</sub> and axial force F<sub>a2</sub> on shaft N<sub>2</sub>

n <sub>2</sub> [rpm]	200		125		75		50		30		10		
	T <sub>2</sub> [Nm]	F <sub>r</sub> [N]	F <sub>a</sub> [N]	F <sub>r</sub> [N]	F <sub>a</sub> [N]	F <sub>r</sub> [N]	F <sub>a</sub> [N]	F <sub>r</sub> [N]	F <sub>a</sub> [N]	F <sub>r</sub> [N]	F <sub>a</sub> [N]	F <sub>r</sub> [N]	F <sub>a</sub> [N]
< 120		2000	1000	2400	1200	2850	1425	3350	1675	4000	2000	4800	2400
> 120		1540	770	1850	925	2190	1095	2580	1290	3080	1540	3700	1850

## Inertia moments/mass

Inertia moment J<sub>1</sub> related to the fast-rotating shaft (N<sub>1</sub>)

	Inertia moment [kgcm <sup>2</sup> ]											
	5:1	7.5:1	10:1	13:1	15:1	20:1	26:1	30:1	40:1	53:1	62:1	83:1
J <sub>1</sub>	0.95	0.73	0.58	0.49	0.60	0.50	0.44	0.57	0.48	0.42	0.47	0.42

The mass of the gearbox may deviate depending on the gear ratio and the type.

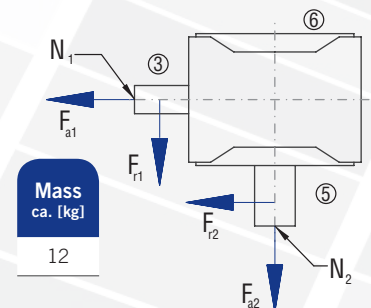

## 9.3.7 Type S 050 – Standard worm gearboxes

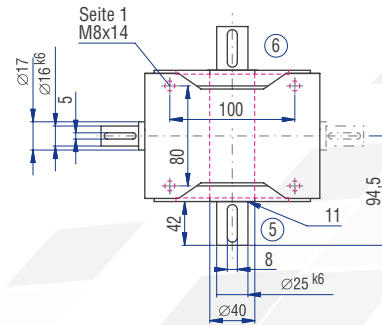
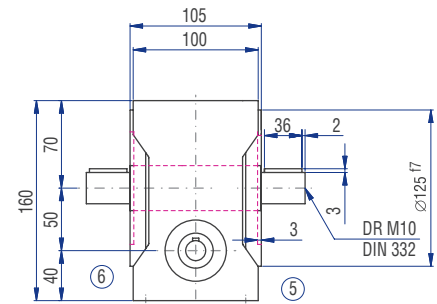
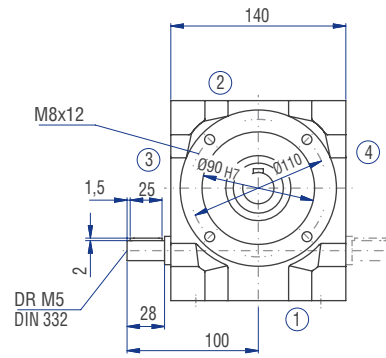
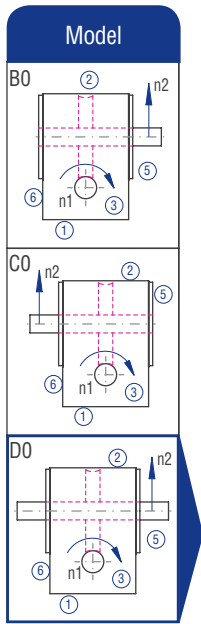

### Implementation VV

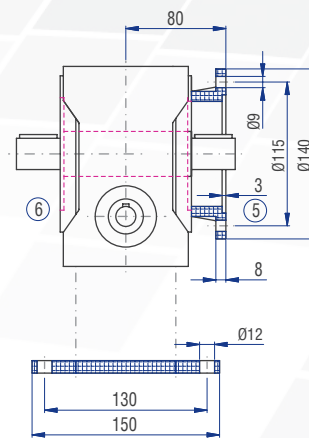
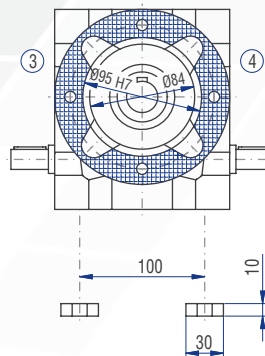
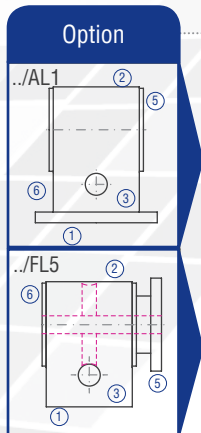
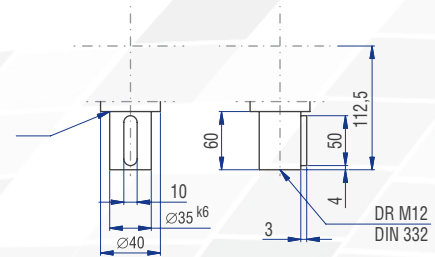



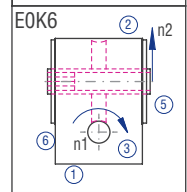
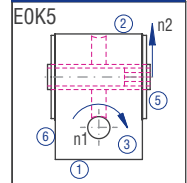
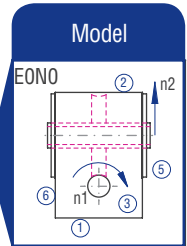
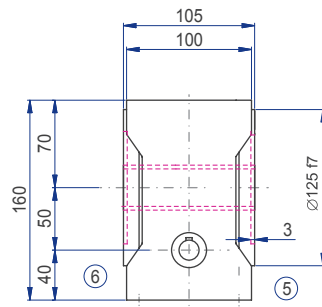
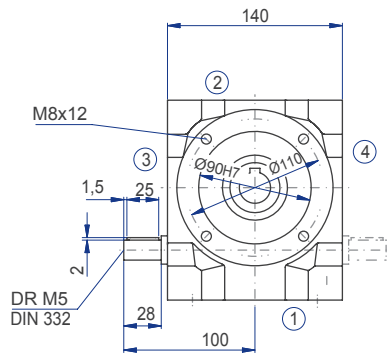

E0N0

E0K5 / E0K6

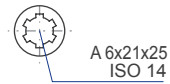
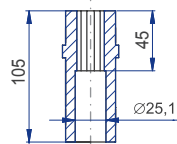
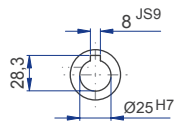
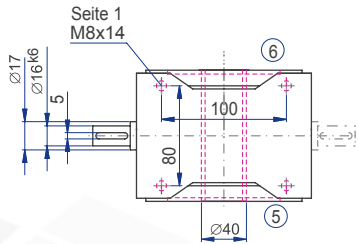

Worm  
gearboxes

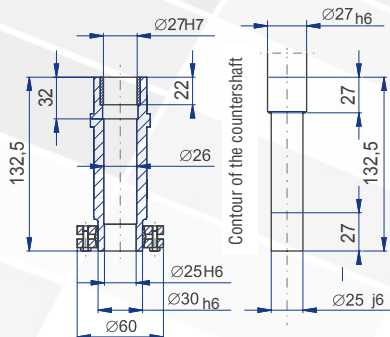
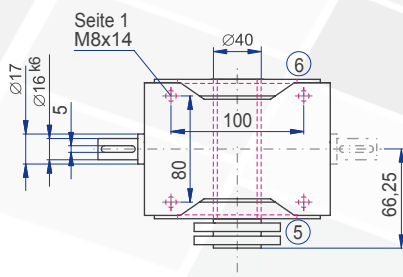
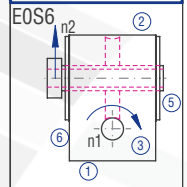
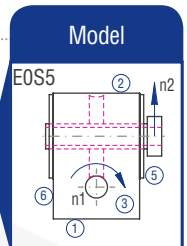
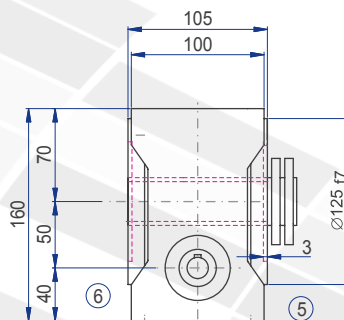
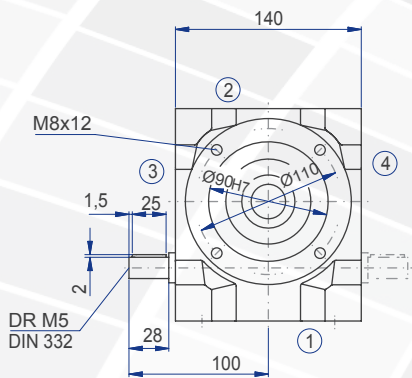

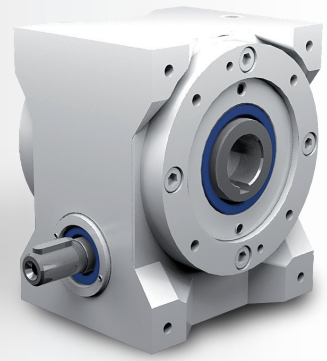

### Characteristics

Characteristic	Standard	Option
<b>Toothing</b>	Hardened and ground worm shaft / bronze worm gear	See chapter 9.2.1
<b>Gear ratio</b>	5:1 to 83:1	
<b>Housing / Flanges</b>	Grey cast iron	
<b>Threaded mounting hole</b>	On gearbox side 1 and on the flanges	See chapter 9.2.3
<b>Shaft</b>	Material 1 C45, shaft ends greased Fit with ISO j6 tolerance with parallel keyway: according to DIN 6885 Sheet 1	See chapter 4.6.2
<b>Hollow shaft</b>	Material 1 C45, shafts greased Fit with ISO H7 tolerance with parallel keyway: according to DIN 6885 Sheet 1	See chapter 4.6.3
<b>Radial shaft seal ring</b>	NBR, form A	See chapter 4.8
<b>Ambient temperature</b>	-10°C to +90°C. The values of the performance tables are valid for 20°C	See chapter 4.9.3
<b>Circumferential backlash</b>	< 30 arcmin	See chapter 9.2.10
<b>Protection class</b>	IP 54	See chapter 4.5
<b>Corrosion protection</b>	Prime coat; layer thickness > 40 µm	See chapter 4.4
<b>Bearing life L10h</b>	more than 15,000h	See chapter 4.9.1
<b>Oil change intervals</b>	Not required if the oil temperature is kept < 90°C The lifetime of the bearings can be increased by the factor 1.5 if the oil is changed after the first 500 service hours and then every 5000 service hours.	See chapter 9.2.8
<b>Lubricant</b>	Synthetic lubricants	See chapter 9.2.8

## Performance data

i	i ist		n <sub>1</sub> [rpm]					
			3000	1500	1000	750	500	150
5:1	29:6	n <sub>2</sub> [rpm]	600.0	300.0	200.0	150.0	100.0	30.0
		P <sub>1N</sub> [kW]	6.37	4.96	3.77	3.11	2.31	0.91
		T <sub>2N</sub> [Nm]	94	145	165	180	198	247
		P <sub>1NT</sub> [kW]	5.80	4.25	3.56	3.15	2.67	0.00
		Efficiency	0.96	0.95	0.95	0.94	0.93	0.88
7.5:1	29:4	n <sub>2</sub> [rpm]	400.0	200.0	133.0	100.0	66.0	20.0
		P <sub>1N</sub> [kW]	4.89	3.62	2.78	2.37	1.79	0.72
		T <sub>2N</sub> [Nm]	106	157	179	201	223	280
		P <sub>1NT</sub> [kW]	4.63	3.26	2.72	2.41	2.06	0.00
		Efficiency	0.94	0.94	0.93	0.92	0.90	0.84
10:1	39:4	n <sub>2</sub> [rpm]	300.0	150.0	100.0	75.0	50.0	15.0
		P <sub>1N</sub> [kW]	4.15	2.94	2.26	1.83	1.30	0.51
		T <sub>2N</sub> [Nm]	121	170	194	207	216	265
		P <sub>1NT</sub> [kW]	4.16	2.89	2.41	2.15	1.86	0.00
		Efficiency	0.94	0.93	0.92	0.91	0.89	0.83
13:1	51:4	n <sub>2</sub> [rpm]	230.0	115.0	76.0	57.0	38.0	11.0
		P <sub>1N</sub> [kW]	3.31	1.81	1.29	1.00	0.71	0.26
		T <sub>2N</sub> [Nm]	125	135	141	145	151	170
		P <sub>1NT</sub> [kW]	3.68	2.53	2.12	1.90	1.66	0.00
		Efficiency	0.93	0.92	0.90	0.89	0.87	0.82
15:1	29:2	n <sub>2</sub> [rpm]	200.0	100.0	66.0	50.0	33.0	10.0
		P <sub>1N</sub> [kW]	3.12	2.23	1.77	1.51	1.16	0.48
		T <sub>2N</sub> [Nm]	128	183	213	240	266	333
		P <sub>1NT</sub> [kW]	2.80	1.95	1.62	1.44	1.23	0.00
		Efficiency	0.89	0.00	0.00	0.86	0.83	0.75
20:1	39:2	n <sub>2</sub> [rpm]	150.0	75.0	50.0	37.0	25.0	7.5
		P <sub>1N</sub> [kW]	2.95	1.70	1.32	1.14	0.86	0.34
		T <sub>2N</sub> [Nm]	161	186	212	237	259	310
		P <sub>1NT</sub> [kW]	2.52	1.73	1.44	1.29	1.12	0.00
		Efficiency	0.88	0.88	0.86	0.84	0.81	0.74

i	i ist		n <sub>1</sub> [rpm]					
			3000	1500	1000	750	500	150
26:1	51:2	n <sub>2</sub> [rpm]	115.0	57.0	38.0	28.0	19.0	5.8
		P <sub>1N</sub> [kW]	1.89	1.25	0.90	0.71	0.51	0.19
		T <sub>2N</sub> [Nm]	132	173	181	187	195	222
		P <sub>1NT</sub> [kW]	2.21	1.52	1.27	1.14	1.01	0.00
		Efficiency	0.86	0.85	0.83	0.81	0.78	0.71
30:1	29:1	n <sub>2</sub> [rpm]	100.0	50.0	33.0	25.0	16.0	5.0
		P <sub>1N</sub> [kW]	1.94	1.38	1.11	0.97	0.75	0.36
		T <sub>2N</sub> [Nm]	143	204	237	268	296	403
		P <sub>1NT</sub> [kW]	1.66	1.15	0.97	0.86	0.75	0.00
		Efficiency	0.80	0.80	0.77	0.75	0.71	0.61
40:1	39:1	n <sub>2</sub> [rpm]	75.0	37.0	25.0	18.0	12.0	3.8
		P <sub>1N</sub> [kW]	1.54	1.08	0.85	0.74	0.57	0.24
		T <sub>2N</sub> [Nm]	149	207	237	264	288	348
		P <sub>1NT</sub> [kW]	1.50	1.04	0.87	0.78	0.69	0.00
		Efficiency	0.78	0.77	0.75	0.72	0.68	0.59
53:1	51:1	n <sub>2</sub> [rpm]	57.0	28.0	18.0	14.0	9.4	2.8
		P <sub>1N</sub> [kW]	1.16	0.80	0.58	0.47	0.34	0.14
		T <sub>2N</sub> [Nm]	143	191	200	207	217	248
		P <sub>1NT</sub> [kW]	1.34	0.96	0.78	0.71	0.63	0.00
		Efficiency	0.76	0.74	0.71	0.68	0.65	0.56
62:1	61:1	n <sub>2</sub> [rpm]	48.0	24.0	16.0	12.0	8.1	2.4
		P <sub>1N</sub> [kW]	0.82	0.66	0.53	0.46	0.34	0.12
		T <sub>2N</sub> [Nm]	110	175	202	221	226	226
		P <sub>1NT</sub> [kW]	1.10	0.76	0.65	0.59	0.52	0.00
		Efficiency	0.69	0.68	0.65	0.62	0.57	0.47
83:1	82:1	n <sub>2</sub> [rpm]	36.0	18.0	12.0	9.0	6.0	1.8
		P <sub>1N</sub> [kW]	0.75	0.46	0.33	0.26	0.19	0.07
		T <sub>2N</sub> [Nm]	129	152	152	152	152	152
		P <sub>1NT</sub> [kW]	0.99	0.69	0.59	0.54	0.49	0.00
		Efficiency	0.66	0.63	0.59	0.56	0.52	0.44

	5:1	7.5:1	10:1	13:1	15:1	20:1	26:1	30:1	40:1	53:1	62:1	83:1
T <sub>2max</sub> [Nm]	295	334	306	222	395	355	295	437	360	310	240	246

## Permissible radial force F<sub>r1</sub> and axial force F<sub>a1</sub> on shaft N<sub>1</sub>

n <sub>1</sub> [rpm]	3000		1500		1000		750		500		150		
	T <sub>1</sub> [Nm]	F <sub>r</sub> [N]	F <sub>a</sub> [N]	F <sub>r</sub> [N]	F <sub>a</sub> [N]	F <sub>r</sub> [N]	F <sub>a</sub> [N]	F <sub>r</sub> [N]	F <sub>a</sub> [N]	F <sub>r</sub> [N]	F <sub>a</sub> [N]	F <sub>r</sub> [N]	F <sub>a</sub> [N]
< 20		820	410	1000	500	1130	565	1320	660	1420	710	1850	925
> 20		630	315	770	385	870	435	1020	510	1090	545	1420	710

## Permissible radial force F<sub>r2</sub> and axial force F<sub>a2</sub> on shaft N<sub>2</sub>

n <sub>2</sub> [rpm]	200		125		75		50		30		10		
	T <sub>2</sub> [Nm]	F <sub>r</sub> [N]	F <sub>a</sub> [N]	F <sub>r</sub> [N]	F <sub>a</sub> [N]	F <sub>r</sub> [N]	F <sub>a</sub> [N]	F <sub>r</sub> [N]	F <sub>a</sub> [N]	F <sub>r</sub> [N]	F <sub>a</sub> [N]	F <sub>r</sub> [N]	F <sub>a</sub> [N]
< 220		2700	1350	3150	1575	3800	1900	4500	2250	5200	2600	5200	2600
> 220		2080	1040	2420	1210	2920	1460	3460	1730	4000	2000	4000	2000

## Inertia moments/mass

Inertia moment J<sub>1</sub> related to the fast-rotating shaft (N<sub>1</sub>)

	Inertia moment [kgcm <sup>2</sup> ]											
	5:1	7.5:1	10:1	13:1	15:1	20:1	26:1	30:1	40:1	53:1	62:1	83:1
J <sub>1</sub>	2.17	1.64	1.14	0.94	1.33	0.94	0.82	1.25	0.90	0.79	0.97	0.80

The mass of the gearbox may deviate depending on the gear ratio and the type.

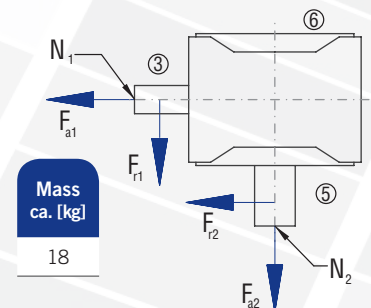

Worm  
gearboxes

## 9.3.8 Type S 063 – Standard worm gearboxes

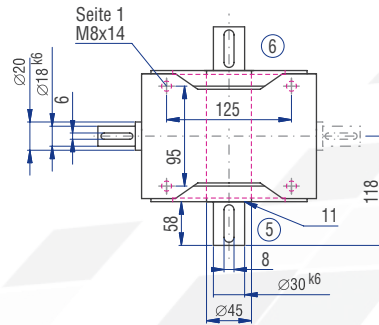
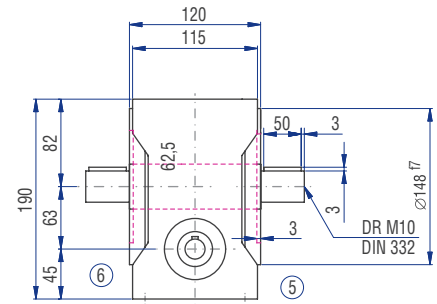
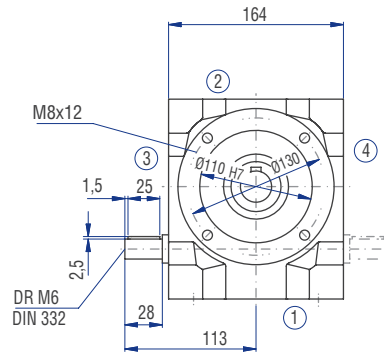
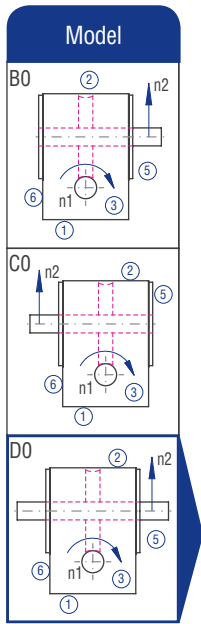

### Implementation VV

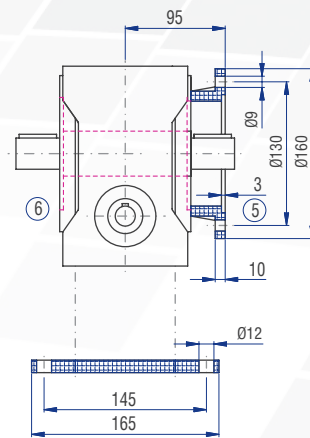
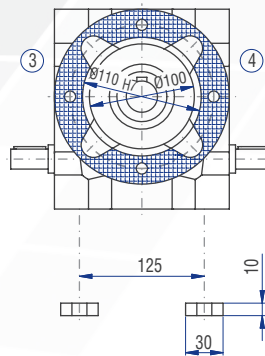
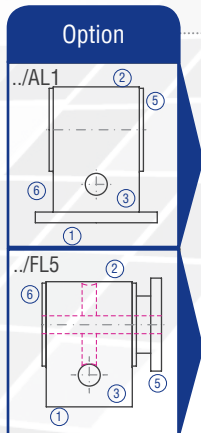
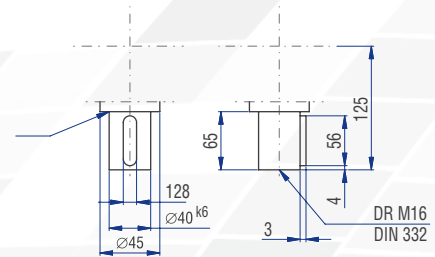

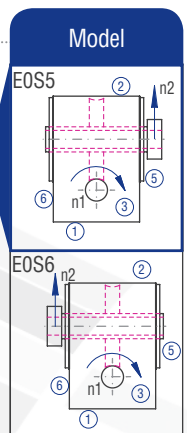
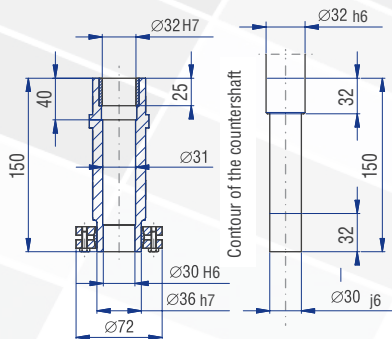
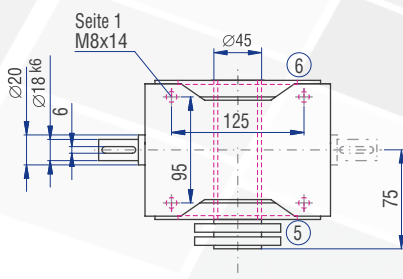
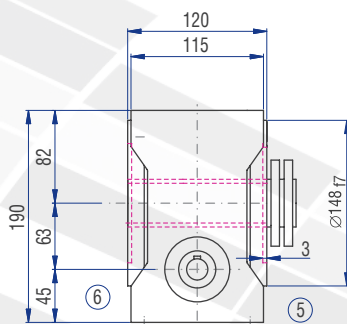
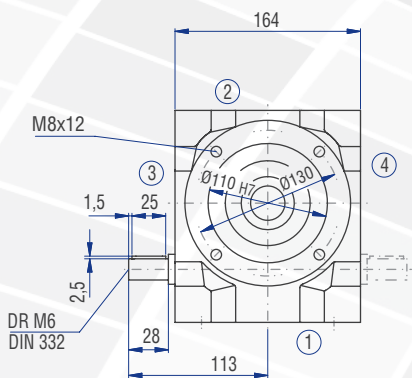
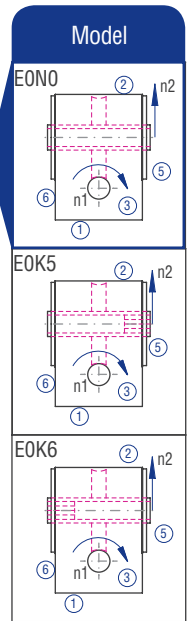
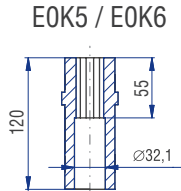
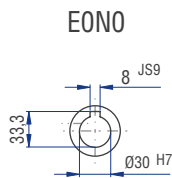
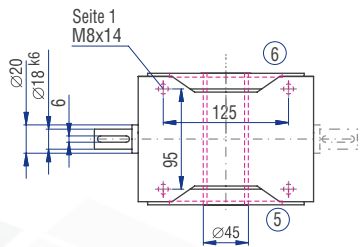
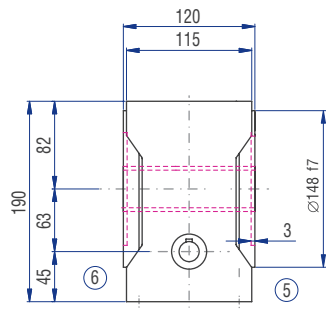
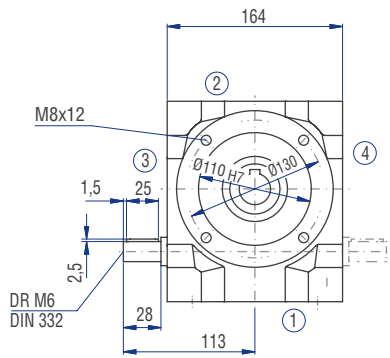

Worm  
gearboxes



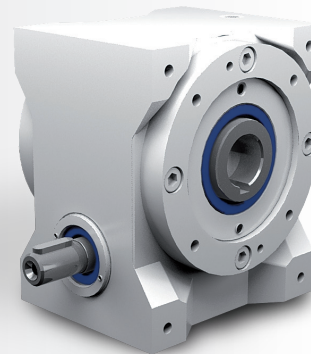

### Characteristics

Characteristic	Standard	Option
<b>Toothing</b>	Hardened and ground worm shaft / bronze worm gear	See chapter 9.2.1
<b>Gear ratio</b>	5:1 to 83:1	
<b>Housing / Flanges</b>	Grey cast iron	
<b>Threaded mounting hole</b>	On gearbox side 1 and on the flanges	See chapter 9.2.3
<b>Shaft</b>	Material 1 C45, shaft ends greased Fit with ISO j6 tolerance with parallel keyway: according to DIN 6885 Sheet 1	See chapter 4.6.2
<b>Hollow shaft</b>	Material 1 C45, shafts greased Fit with ISO H7 tolerance with parallel keyway: according to DIN 6885 Sheet 1	See chapter 4.6.3
<b>Radial shaft seal ring</b>	NBR, form A	See chapter 4.8
<b>Ambient temperature</b>	-10°C to +90°C. The values of the performance tables are valid for 20°C	See chapter 4.9.3
<b>Circumferential backlash</b>	< 30 arcmin	See chapter 9.2.10
<b>Protection class</b>	IP 54	See chapter 4.5
<b>Corrosion protection</b>	Prime coat; layer thickness > 40 µm	See chapter 4.4
<b>Bearing life L10h</b>	more than 15,000h	See chapter 4.9.1
<b>Oil change intervals</b>	Not required if the oil temperature is kept < 90°C The lifetime of the bearings can be increased by the factor 1.5 if the oil is changed after the first 500 service hours and then every 5000 service hours.	See chapter 9.2.8
<b>Lubricant</b>	Synthetic lubricants	See chapter 9.2.8

## Performance data

i	i ist		n <sub>1</sub> [rpm]					
			3000	1500	1000	750	500	150
5:1	30:6	n <sub>2</sub> [rpm]	600.0	300.0	200.0	150.0	100.0	30.0
		P <sub>1N</sub> [kW]	11.13	8.18	4.36	5.55	4.01	1.58
		T <sub>2N</sub> [Nm]	170	250	298	332	360	448
		P <sub>1NT</sub> [kW]	8.62	6.68	5.70	5.05	4.24	0.00
		Efficiency	0.96	0.96	0.95	0.94	0.94	0.89
7.5:1	30:4	n <sub>2</sub> [rpm]	400.0	200.0	133.0	100.0	66.0	20.0
		P <sub>1N</sub> [kW]	8.64	6.37	5.01	4.36	3.33	1.39
		T <sub>2N</sub> [Nm]	196	289	341	391	439	569
		P <sub>1NT</sub> [kW]	6.69	5.14	4.37	3.88	3.27	0.00
		Efficiency	0.95	0.95	0.95	0.94	0.92	0.86
10:1	40:4	n <sub>2</sub> [rpm]	300.0	150.0	100.0	75.0	50.0	15.0
		P <sub>1N</sub> [kW]	6.58	4.96	3.79	3.15	2.35	0.96
		T <sub>2N</sub> [Nm]	197	297	340	373	408	513
		P <sub>1NT</sub> [kW]	5.92	4.47	3.79	3.36	2.86	0.00
		Efficiency	0.94	0.94	0.94	0.93	0.91	0.84
13:1	53:4	n <sub>2</sub> [rpm]	230.0	115.0	76.0	57.0	38.0	11.0
		P <sub>1N</sub> [kW]	4.41	2.41	1.70	1.33	0.94	0.34
		T <sub>2N</sub> [Nm]	173	187	196	202	210	236
		P <sub>1NT</sub> [kW]	5.27	3.91	3.32	2.96	2.56	0.00
		Efficiency	0.93	0.92	0.91	0.90	0.88	0.83
15:1	30:2	n <sub>2</sub> [rpm]	200.0	100.0	66.0	50.0	33.0	10.0
		P <sub>1N</sub> [kW]	5.61	4.10	3.26	2.81	2.18	0.93
		T <sub>2N</sub> [Nm]	241	352	415	473	530	681
		P <sub>1NT</sub> [kW]	4.08	3.09	2.62	2.32	1.97	0.00
		Efficiency	0.90	0.90	0.89	0.88	0.85	0.77
20:1	40:2	n <sub>2</sub> [rpm]	150.0	75.0	50.0	37.0	25.0	7.5
		P <sub>1N</sub> [kW]	4.24	3.04	2.37	2.05	1.57	0.64
		T <sub>2N</sub> [Nm]	240	344	399	450	498	615
		P <sub>1NT</sub> [kW]	3.59	2.67	2.26	2.01	1.72	0.00
		Efficiency	0.89	0.89	0.88	0.86	0.83	0.75

i	i ist		n <sub>1</sub> [rpm]					
			3000	1500	1000	750	500	150
26:1	53:2	n <sub>2</sub> [rpm]	115.0	57.0	38.0	28.0	19.0	5.8
		P <sub>1N</sub> [kW]	2.83	1.67	1.19	0.94	0.68	0.25
		T <sub>2N</sub> [Nm]	210	245	256	264	275	312
		P <sub>1NT</sub> [kW]	3.19	2.34	1.99	1.78	1.55	0.00
		Efficiency	0.88	0.87	0.85	0.83	0.80	0.73
30:1	30:1	n <sub>2</sub> [rpm]	100.0	50.0	33.0	25.0	16.0	5.0
		P <sub>1N</sub> [kW]	3.47	2.52	2.03	1.78	1.38	0.63
		T <sub>2N</sub> [Nm]	272	395	456	530	593	760
		P <sub>1NT</sub> [kW]	2.41	1.81	1.54	1.38	1.18	0.00
		Efficiency	0.82	0.82	0.80	0.78	0.75	0.63
40:1	40:1	n <sub>2</sub> [rpm]	75.0	37.0	25.0	18.0	12.0	3.8
		P <sub>1N</sub> [kW]	2.62	1.87	1.49	1.31	1.02	0.40
		T <sub>2N</sub> [Nm]	267	381	443	501	553	625
		P <sub>1NT</sub> [kW]	2.14	1.58	1.35	1.21	1.05	0.00
		Efficiency	0.80	0.80	0.78	0.75	0.71	0.61
53:1	53:1	n <sub>2</sub> [rpm]	57.0	28.0	18.0	14.0	9.4	2.8
		P <sub>1N</sub> [kW]	1.78	1.04	0.76	0.61	0.45	0.18
		T <sub>2N</sub> [Nm]	234	271	284	294	308	352
		P <sub>1NT</sub> [kW]	1.93	1.41	1.20	1.09	0.96	0.00
		Efficiency	0.78	0.77	0.74	0.71	0.68	0.58
62:1	62:1	n <sub>2</sub> [rpm]	48.0	24.0	16.0	12.0	8.1	2.4
		P <sub>1N</sub> [kW]	1.40	1.01	0.81	0.69	0.54	0.23
		T <sub>2N</sub> [Nm]	194	279	325	352	393	448
		P <sub>1NT</sub> [kW]	1.55	1.15	0.98	0.89	0.78	0.00
		Efficiency	0.70	0.70	0.68	0.65	0.61	0.49
83:1	82:1	n <sub>2</sub> [rpm]	36.0	18.0	12.0	9.0	6.0	1.8
		P <sub>1N</sub> [kW]	1.10	0.90	0.64	0.49	0.35	0.13
		T <sub>2N</sub> [Nm]	196	304	304	304	304	304
		P <sub>1NT</sub> [kW]	1.43	1.04	0.90	0.82	0.73	0.00
		Efficiency	0.68	0.65	0.61	0.59	0.55	0.46

	5:1	7.5:1	10:1	13:1	15:1	20:1	26:1	30:1	40:1	53:1	62:1	83:1
T <sub>2max</sub> [Nm]	610	695	625	321	826	725	432	920	780	480	480	510

## Permissible radial force F<sub>r1</sub> and axial force F<sub>a1</sub> on shaft N<sub>1</sub>

n <sub>1</sub> [rpm]	3000		1500		1000		750		500		150	
T <sub>1</sub> [Nm]	F <sub>r</sub> [N]	F <sub>a</sub> [N]	F <sub>r</sub> [N]	F <sub>a</sub> [N]	F <sub>r</sub> [N]	F <sub>a</sub> [N]	F <sub>r</sub> [N]	F <sub>a</sub> [N]	F <sub>r</sub> [N]	F <sub>a</sub> [N]	F <sub>r</sub> [N]	F <sub>a</sub> [N]
< 35	1000	500	1250	625	1420	710	1600	800	1780	890	2200	1100
> 35	770	385	960	480	1090	545	1230	615	1470	735	1690	845

## Permissible radial force F<sub>r2</sub> and axial force F<sub>a2</sub> on shaft N<sub>2</sub>

n <sub>2</sub> [rpm]	200		125		75		50		30		10	
T <sub>2</sub> [Nm]	F <sub>r</sub> [N]	F <sub>a</sub> [N]	F <sub>r</sub> [N]	F <sub>a</sub> [N]	F <sub>r</sub> [N]	F <sub>a</sub> [N]	F <sub>r</sub> [N]	F <sub>a</sub> [N]	F <sub>r</sub> [N]	F <sub>a</sub> [N]	F <sub>r</sub> [N]	F <sub>a</sub> [N]
< 430	3300	1650	3750	1875	4500	2250	5300	2650	6300	3150	7600	3800
> 430	2640	1320	3000	1500	3600	1800	4240	2120	5040	2520	6080	3040

## Inertia moments/mass

Inertia moment J<sub>1</sub> related to the fast-rotating shaft (N<sub>1</sub>)

	Inertia moment [kgcm <sup>2</sup> ]											
	5:1	7.5:1	10:1	13:1	15:1	20:1	26:1	30:1	40:1	53:1	62:1	83:1
J <sub>1</sub>	5.82	4.22	2.96	2.26	3.26	2.40	1.91	3.01	2.26	1.82	2.51	1.91

The mass of the gearbox may deviate depending on the gear ratio and the type.

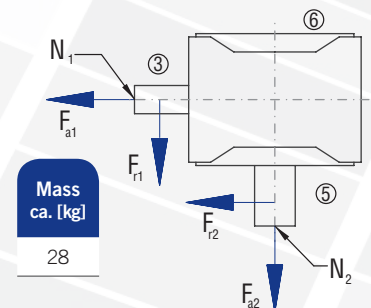

Worm  
gearboxes

# 9.3.9 Type S 080 – Standard worm gearboxes

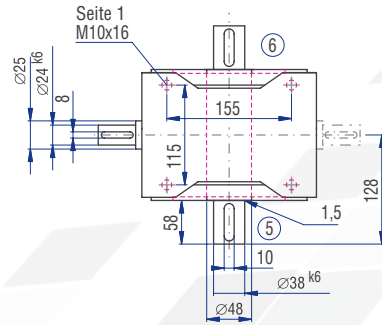
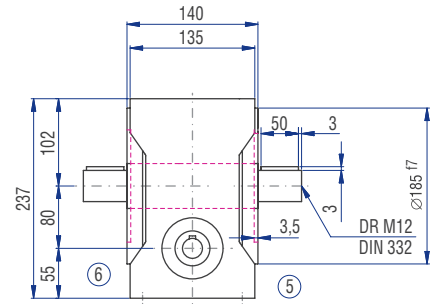
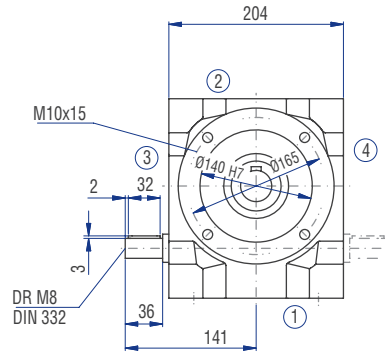
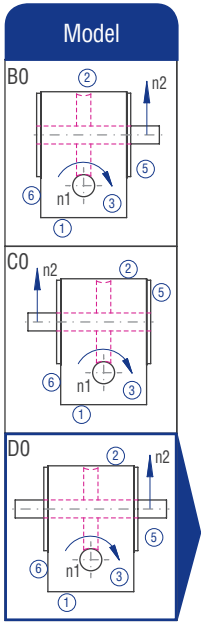

## Implementation VV

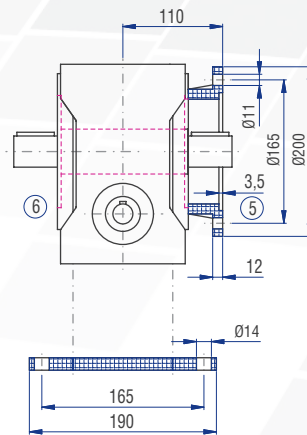
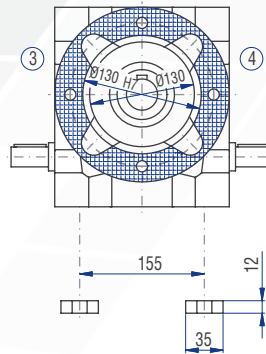
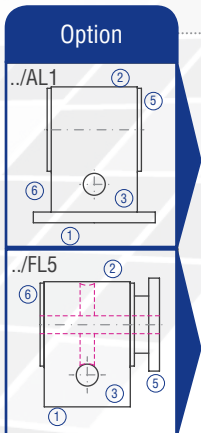
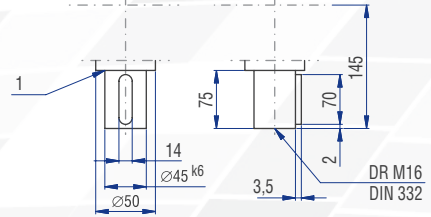

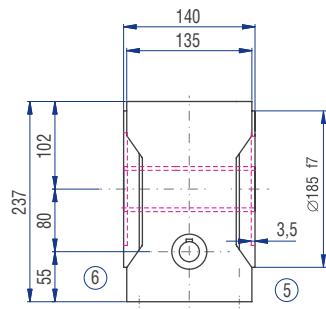
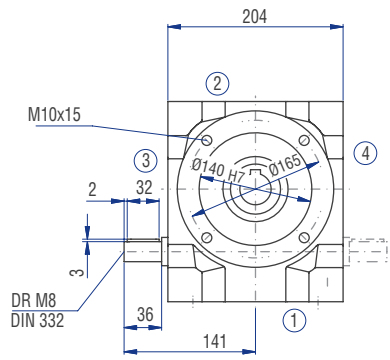

EON0

EOK5 / EOK6

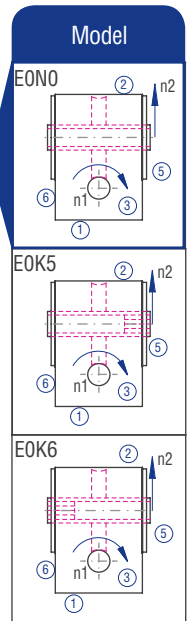
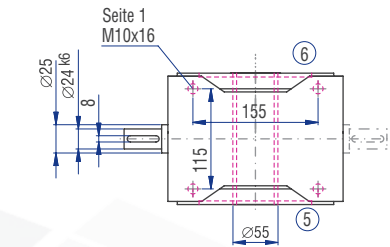
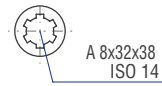
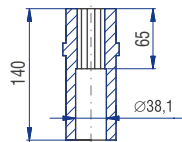
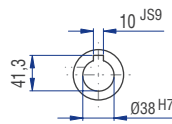

Worm gearboxes

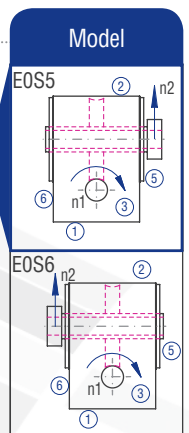
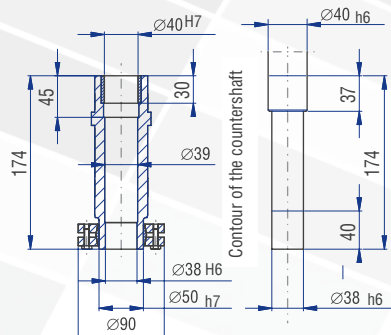
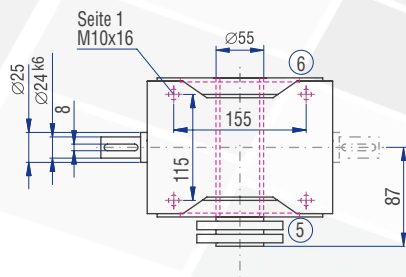
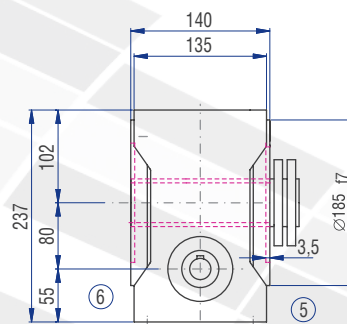
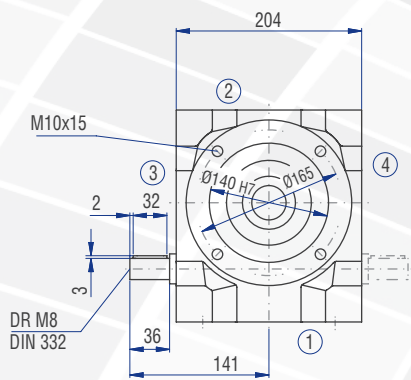

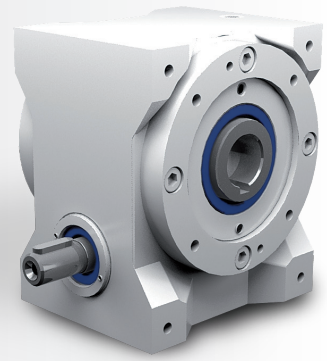

### Characteristics

Characteristic	Standard	Option
<b>Toothing</b>	Hardened and ground worm shaft / bronze worm gear	See chapter 9.2.1
<b>Gear ratio</b>	5:1 to 83:1	
<b>Housing / Flanges</b>	Grey cast iron	
<b>Threaded mounting hole</b>	On gearbox side 1 and on the flanges	See chapter 9.2.3
<b>Shaft</b>	Material 1 C45, shaft ends greased Fit with ISO j6 tolerance with parallel keyway: according to DIN 6885 Sheet 1	See chapter 4.6.2
<b>Hollow shaft</b>	Material 1 C45, shafts greased Fit with ISO H7 tolerance with parallel keyway: according to DIN 6885 Sheet 1	See chapter 4.6.3
<b>Radial shaft seal ring</b>	NBR, form A	See chapter 4.8
<b>Ambient temperature</b>	-10°C to +90°C. The values of the performance tables are valid for 20°C	See chapter 4.9.3
<b>Circumferential backlash</b>	< 30 arcmin	See chapter 9.2.10
<b>Protection class</b>	IP 54	See chapter 4.5
<b>Corrosion protection</b>	Prime coat; layer thickness > 40 µm	See chapter 4.4
<b>Bearing life L10h</b>	more than 15,000h	See chapter 4.9.1
<b>Oil change intervals</b>	Not required if the oil temperature is kept < 90°C The lifetime of the bearings can be increased by the factor 1.5 if the oil is changed after the first 500 service hours and then every 5000 service hours.	See chapter 9.2.8
<b>Lubricant</b>	Synthetic lubricants	See chapter 9.2.8



## Performance data

i	i ist		n <sub>1</sub> [1/min]					
			3000	1500	1000	750	500	150
5:1	30:6	n <sub>2</sub> [1/min]	600,0	300,0	200,0	150,0	100,0	30,0
		P <sub>1N</sub> [kW]	29,45	19,31	14,99	12,45	9,47	4,01
		T <sub>2N</sub> [Nm]	450	590	680	745	850	1.150
		P <sub>1NT</sub> [kW]	11,30	8,60	7,55	6,87	5,96	0,00
		Wirkungsgrad	0,96	0,96	0,95	0,94	0,94	0,90
7,5:1	30:4	n <sub>2</sub> [1/min]	400,0	200,0	133,0	100,0	66,0	20,0
		P <sub>1N</sub> [kW]	22,62	14,33	10,92	9,10	7,00	3,03
		T <sub>2N</sub> [Nm]	513	650	743	817	932	1.258
		P <sub>1NT</sub> [kW]	9,06	6,85	5,99	5,43	4,71	0,00
		Wirkungsgrad	0,95	0,95	0,95	0,94	0,93	0,87
10:1	40:4	n <sub>2</sub> [1/min]	300,0	150,0	100,0	75,0	50,0	15,0
		P <sub>1N</sub> [kW]	18,55	11,75	8,95	7,45	5,79	2,02
		T <sub>2N</sub> [Nm]	555	703	803	882	1.006	1.095
		P <sub>1NT</sub> [kW]	8,57	6,35	5,49	4,95	4,30	0,00
		Wirkungsgrad	0,94	0,94	0,94	0,93	0,91	0,85
13:1	52:4	n <sub>2</sub> [1/min]	230,0	115,0	76,0	57,0	38,0	11,0
		P <sub>1N</sub> [kW]	11,09	6,09	4,30	3,37	2,37	0,85
		T <sub>2N</sub> [Nm]	427	464	486	502	523	586
		P <sub>1NT</sub> [kW]	7,87	5,73	4,92	4,43	3,85	0,00
		Wirkungsgrad	0,93	0,92	0,91	0,90	0,89	0,83
15:1	30:2	n <sub>2</sub> [1/min]	200,0	100,0	66,0	50,0	33,0	10,0
		P <sub>1N</sub> [kW]	13,12	8,32	6,41	5,34	4,16	1,88
		T <sub>2N</sub> [Nm]	564	715	817	898	1.025	1.386
		P <sub>1NT</sub> [kW]	5,76	4,31	3,75	3,40	2,95	0,00
		Wirkungsgrad	0,90	0,90	0,89	0,88	0,86	0,77
20:1	40:2	n <sub>2</sub> [1/min]	150,0	75,0	50,0	37,0	25,0	7,5
		P <sub>1N</sub> [kW]	10,84	6,87	5,28	4,45	3,47	1,49
		T <sub>2N</sub> [Nm]	614	778	888	975	1.112	1.441
		P <sub>1NT</sub> [kW]	5,44	3,99	3,44	3,10	2,69	0,00
		Wirkungsgrad	0,89	0,89	0,88	0,86	0,84	0,76

i	i ist		n <sub>1</sub> [1/min]					
			3000	1500	1000	750	500	150
26:1	52:2	n <sub>2</sub> [1/min]	115,0	57,0	38,0	28,0	19,0	5,8
		P <sub>1N</sub> [kW]	7,63	4,20	3,00	2,38	1,72	0,64
		T <sub>2N</sub> [Nm]	556	605	634	655	683	773
		P <sub>1NT</sub> [kW]	4,94	3,57	3,06	2,75	2,40	0,00
		Wirkungsgrad	0,88	0,87	0,85	0,83	0,80	0,73
30:1	30:1	n <sub>2</sub> [1/min]	100,0	50,0	33,0	25,0	16,0	5,0
		P <sub>1N</sub> [kW]	7,53	4,78	3,60	3,19	2,51	1,18
		T <sub>2N</sub> [Nm]	590	748	825	950	1.080	1.437
		P <sub>1NT</sub> [kW]	3,50	2,60	2,27	2,06	1,81	0,00
		Wirkungsgrad	0,82	0,82	0,80	0,78	0,75	0,64
40:1	40:1	n <sub>2</sub> [1/min]	75,0	37,0	25,0	18,0	12,0	3,8
		P <sub>1N</sub> [kW]	6,33	4,01	3,13	2,65	2,13	1,00
		T <sub>2N</sub> [Nm]	645	817	933	1.025	1.169	1.581
		P <sub>1NT</sub> [kW]	3,32	2,42	2,09	1,90	1,67	0,00
		Wirkungsgrad	0,80	0,80	0,78	0,76	0,72	0,62
53:1	52:1	n <sub>2</sub> [1/min]	57,0	28,0	18,0	14,0	9,4	2,8
		P <sub>1N</sub> [kW]	4,76	2,63	1,92	1,53	1,11	0,45
		T <sub>2N</sub> [Nm]	615	670	704	728	762	870
		P <sub>1NT</sub> [kW]	3,04	2,19	1,88	1,71	1,51	0,00
		Wirkungsgrad	0,78	0,77	0,74	0,72	0,69	0,59
62:1	63:1	n <sub>2</sub> [1/min]	48,0	24,0	16,0	12,0	8,1	2,4
		P <sub>1N</sub> [kW]	4,59	2,91	2,17	1,70	1,21	0,44
		T <sub>2N</sub> [Nm]	645	817	886	886	886	886
		P <sub>1NT</sub> [kW]	2,39	1,74	1,52	1,39	1,24	0,00
		Wirkungsgrad	0,70	0,70	0,68	0,65	0,61	0,50
83:1	82:1	n <sub>2</sub> [1/min]	36,0	18,0	12,0	9,0	6,0	1,8
		P <sub>1N</sub> [kW]	3,33	1,74	1,23	0,94	0,67	0,24
		T <sub>2N</sub> [Nm]	591	599	599	599	599	599
		P <sub>1NT</sub> [kW]	2,24	1,61	1,40	1,28	1,15	0,00
		Wirkungsgrad	0,68	0,66	0,62	0,61	0,57	0,47

	5:1	7,5:1	10:1	13:1	15:1	20:1	26:1	30:1	40:1	53:1	62:1	83:1
T <sub>2max</sub> [Nm]	1190	1360	1090	736	1610	1440	980	1765	1582	1080	1040	1000

## Permissible radial force F<sub>r1</sub> and axial force F<sub>a1</sub> on shaft N<sub>1</sub>

n <sub>1</sub> [rpm]	3000		1500		1000		750		500		150	
	T <sub>1</sub> [Nm]	F <sub>r</sub> [N]	F <sub>a</sub> [N]	F <sub>r</sub> [N]	F <sub>a</sub> [N]	F <sub>r</sub> [N]	F <sub>a</sub> [N]	F <sub>r</sub> [N]	F <sub>a</sub> [N]	F <sub>r</sub> [N]	F <sub>a</sub> [N]	F <sub>r</sub> [N]
< 80	1250	625	1600	800	1800	900	2000	1000	2250	1125	2650	1325
> 80	960	480	1230	615	1380	690	1540	770	1730	865	2040	1020

## Permissible radial force F<sub>r2</sub> and axial force F<sub>a2</sub> on shaft N<sub>2</sub>

n <sub>2</sub> [rpm]	200		125		75		50		30		10	
	T <sub>2</sub> [Nm]	F <sub>r</sub> [N]	F <sub>a</sub> [N]	F <sub>r</sub> [N]	F <sub>a</sub> [N]	F <sub>r</sub> [N]	F <sub>a</sub> [N]	F <sub>r</sub> [N]	F <sub>a</sub> [N]	F <sub>r</sub> [N]	F <sub>a</sub> [N]	F <sub>r</sub> [N]
< 800	3650	1825	4000	2000	4750	2375	5600	2800	6700	3350	9500	4750
> 800	2920	1460	3200	1600	3800	1900	4480	2240	5360	2680	7600	3800

## Inertia moments/mass

Inertia moment J<sub>1</sub> related to the fast-rotating shaft (N<sub>1</sub>)

	Inertia moment [kgcm <sup>2</sup> ]											
	5:1	7,5:1	10:1	13:1	15:1	20:1	26:1	30:1	40:1	53:1	62:1	83:1
J <sub>1</sub>	22.38	17.88	14.03	12.28	15.17	12.37	11.34	14.50	11.96	11.10	12.56	11.34

The mass of the gearbox may deviate depending on the gear ratio and the type.

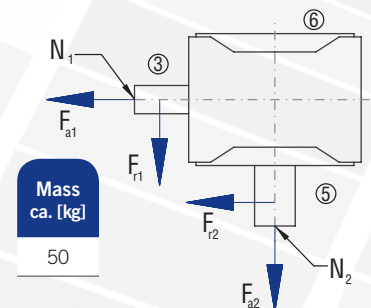

# 9.3.10 Type S 100 – Standard worm gearboxes

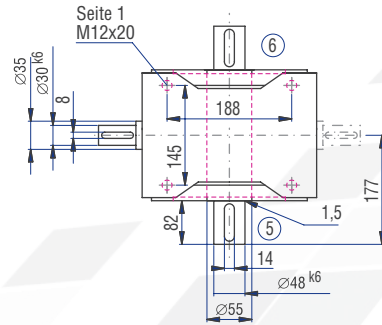
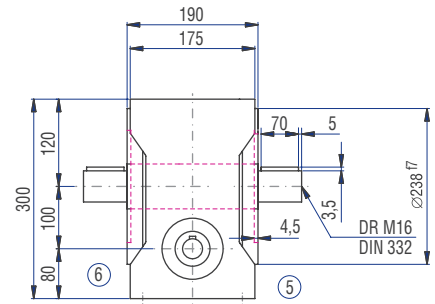
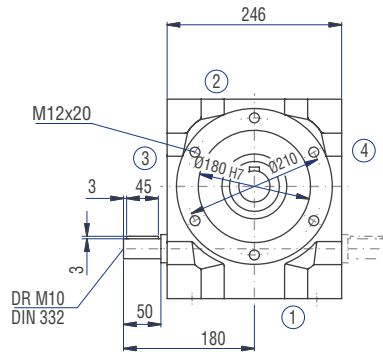
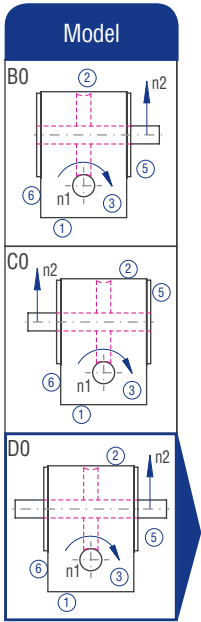

## Implementation VV

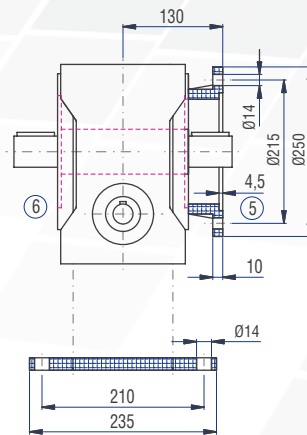
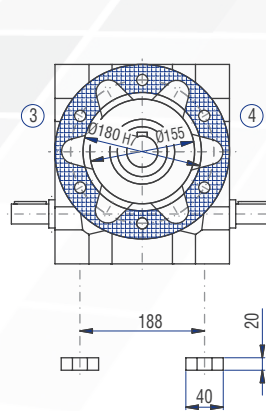
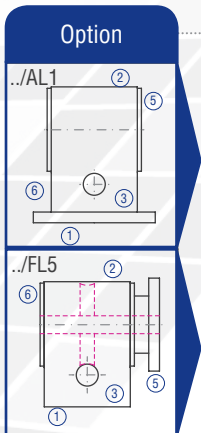
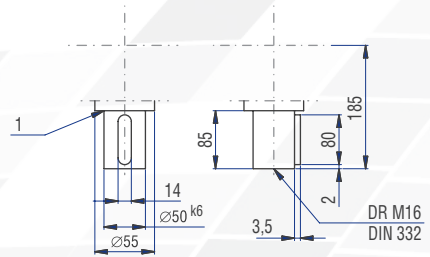

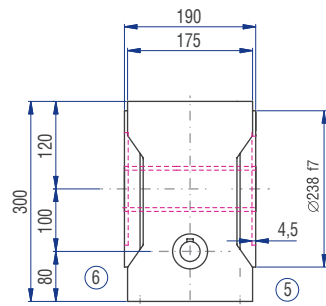
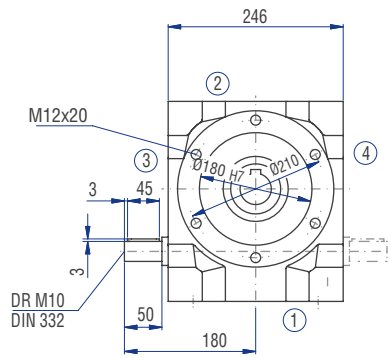

EON0

EOK5 / EOK6

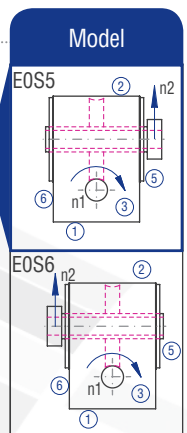
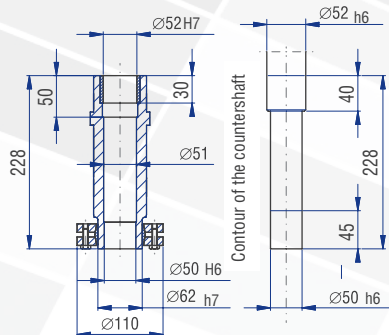
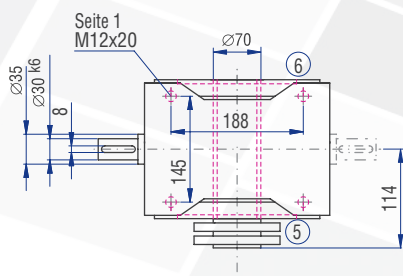
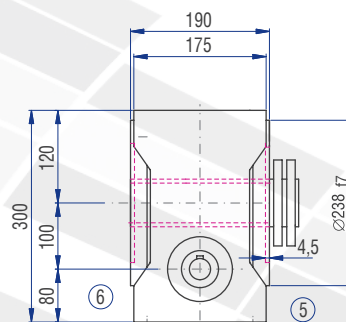
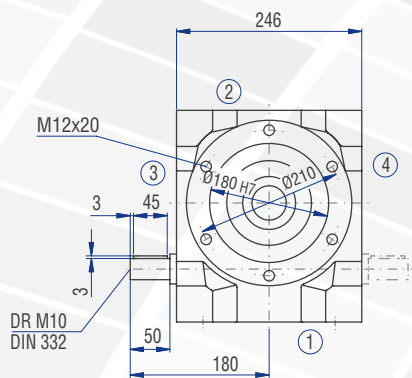
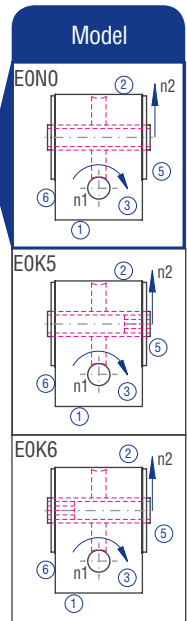
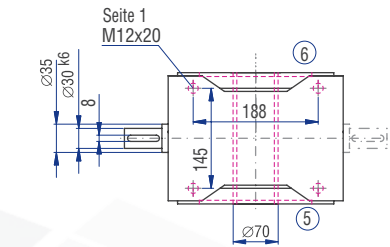
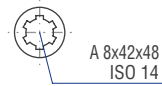
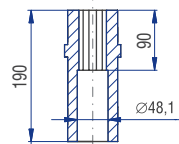
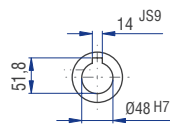

Worm  
gearboxes

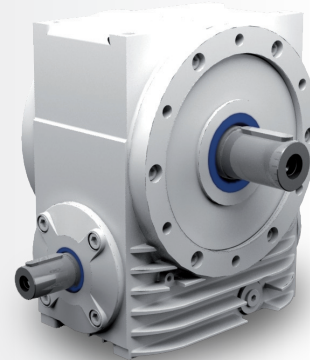

### Characteristics

Characteristic	Standard	Option
<b>Toothing</b>	Hardened and ground worm shaft / bronze worm gear	See chapter 9.2.1
<b>Gear ratio</b>	5:1 to 83:1	
<b>Housing / Flanges</b>	Grey cast iron	
<b>Threaded mounting hole</b>	On gearbox sides 1, 2 and on the flanges	See chapter 9.2.3
<b>Shaft</b>	Material 1 C45, shaft ends greased Fit with ISO j6 tolerance with parallel keyway: according to DIN 6885 Sheet 1	See chapter 4.6.2
<b>Hollow shaft</b>	Material: GGG grey cast iron; shafts greased Fit with ISO H7 tolerance with parallel keyway: according to DIN 6885 Sheet 1	See chapter 4.6.3
<b>Radial shaft seal ring</b>	NBR, form A	See chapter 4.8
<b>Ambient temperature</b>	-10°C to +90°C. The values of the performance tables are valid for 20°C	See chapter 4.9.3
<b>Circumferential backlash</b>	< 30 arcmin	See chapter 9.2.10
<b>Protection class</b>	IP 54	See chapter 4.5
<b>Corrosion protection</b>	Prime coat; layer thickness > 40 µm	See chapter 4.4
<b>Bearing life L10h</b>	more than 15,000h	See chapter 4.9.1
<b>Oil change intervals</b>	Not required if the oil temperature is kept < 90°C The lifetime of the bearings can be increased by the factor 1.5 if the oil is changed after the first 500 service hours and then every 5000 service hours.	See chapter 9.2.8
<b>Lubricant</b>	Synthetic lubricants	See chapter 9.2.8

## Performance data

i	i ist		n <sub>1</sub> [rpm]					
			3000	1500	1000	750	500	150
5:1	29:6	n <sub>2</sub> [rpm]	600.0	300.0	200.0	150.0	100.0	30.0
		P <sub>1N</sub> [kW]	42.41	30.32	23.15	19.34	14.72	6.29
		T <sub>2N</sub> [Nm]	626	895	1,025	1,130	1,290	1,760
		P <sub>1NT</sub> [kW]	17.93	14.48	13.01	11.94	10.40	0.00
		Efficiency	0.96	0.96	0.96	0.95	0.95	0.91
7.5:1	29:4	n <sub>2</sub> [rpm]	400.0	200.0	133.0	100.0	66.0	20.0
		P <sub>1N</sub> [kW]	35.71	22.49	17.13	14.13	11.03	4.96
		T <sub>2N</sub> [Nm]	738	986	1,127	1,239	1,436	2,016
		P <sub>1NT</sub> [kW]	14.40	11.53	10.31	9.44	8.20	0.00
		Efficiency	0.95	0.95	0.95	0.95	0.94	0.88
10:1	40:4	n <sub>2</sub> [rpm]	300.0	150.0	100.0	75.0	50.0	15.0
		P <sub>1N</sub> [kW]	28.41	17.86	13.61	11.22	8.62	3.78
		T <sub>2N</sub> [Nm]	850	1,069	1,222	1,343	1,532	2,092
		P <sub>1NT</sub> [kW]	13.62	10.68	9.41	8.54	7.37	0.00
		Efficiency	0.94	0.94	0.94	0.94	0.93	0.87
13:1	52:4	n <sub>2</sub> [rpm]	230.0	115.0	76.0	57.0	38.0	11.0
		P <sub>1N</sub> [kW]	18.19	10.02	7.00	5.42	3.86	1.37
		T <sub>2N</sub> [Nm]	700	763	800	826	862	966
		P <sub>1NT</sub> [kW]	12.83	9.84	8.56	7.72	6.65	0.00
		Efficiency	0.93	0.92	0.92	0.92	0.90	0.85
15:1	29:2	n <sub>2</sub> [rpm]	200.0	100.0	66.0	50.0	33.0	10.0
		P <sub>1N</sub> [kW]	20.06	12.61	10.01	8.88	6.91	3.21
		T <sub>2N</sub> [Nm]	862	1,084	1,290	1,510	1,743	2,423
		P <sub>1NT</sub> [kW]	9.13	7.24	6.44	5.88	5.10	0.00
		Efficiency	0.90	0.90	0.90	0.89	0.88	0.79
20:1	40:2	n <sub>2</sub> [rpm]	150.0	75.0	50.0	37.0	25.0	7.5
		P <sub>1N</sub> [kW]	16.59	10.44	7.95	6.74	5.23	2.33
		T <sub>2N</sub> [Nm]	940	1,183	1,352	1,510	1,717	2,310
		P <sub>1NT</sub> [kW]	8.61	6.68	5.86	5.31	4.58	0.00
		Efficiency	0.89	0.89	0.89	0.88	0.86	0.78

	5:1	7.5:1	10:1	13:1	15:1	20:1	26:1	30:1	40:1	53:1	62:1	83:1
T <sub>2max</sub> [Nm]	2250	2250	2250	1190	2250	2392	1630	2270	2320	1810	2010	1950

## Permissible radial force F<sub>r1</sub> and axial force F<sub>a1</sub> on shaft N<sub>1</sub>

n <sub>1</sub> [rpm]	3000		1500		1000		750		500		150	
	F <sub>r</sub> [N]	F <sub>a</sub> [N]	F <sub>r</sub> [N]	F <sub>a</sub> [N]	F <sub>r</sub> [N]	F <sub>a</sub> [N]	F <sub>r</sub> [N]	F <sub>a</sub> [N]	F <sub>r</sub> [N]	F <sub>a</sub> [N]	F <sub>r</sub> [N]	F <sub>a</sub> [N]
< 120	2000	1000	2500	1250	2800	1400	3100	1550	3500	1750	4000	2000
> 120	1540	770	1920	960	2150	1075	2390	1195	2690	1345	3070	1535

## Permissible radial force F<sub>r2</sub> and axial force F<sub>a2</sub> on shaft N<sub>2</sub>

n <sub>2</sub> [rpm]	200		125		75		50		30		10	
	F <sub>r</sub> [N]	F <sub>a</sub> [N]	F <sub>r</sub> [N]	F <sub>a</sub> [N]	F <sub>r</sub> [N]	F <sub>a</sub> [N]	F <sub>r</sub> [N]	F <sub>a</sub> [N]	F <sub>r</sub> [N]	F <sub>a</sub> [N]	F <sub>r</sub> [N]	F <sub>a</sub> [N]
< 1300	4700	2350	5300	2650	6300	3150	7500	3750	9000	4500	11000	5500
> 1300	3760	1880	4240	2120	5040	2520	6000	3000	7200	3600	8800	4400

## Inertia moments/mass

Inertia moment J<sub>1</sub> related to the fast-rotating shaft (N<sub>1</sub>)

	Inertia moment [kgcm <sup>2</sup> ]											
	5:1	7.5:1	10:1	13:1	15:1	20:1	26:1	30:1	40:1	53:1	62:1	83:1
J <sub>1</sub>	41.77	35.71	26.58	22.54	32.07	23.93	20.71	31.17	23.26	20.25	25.06	21.04

The mass of the gearbox may deviate depending on the gear ratio and the type.

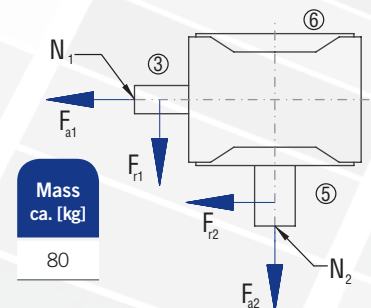

Worm gearboxes

# 9.3.11 Type S 125 – Standard worm gearboxes

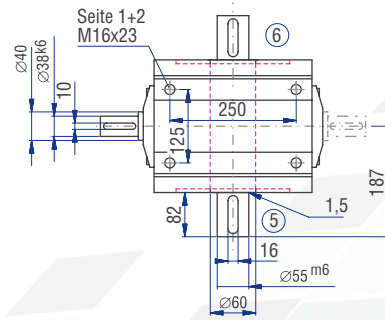
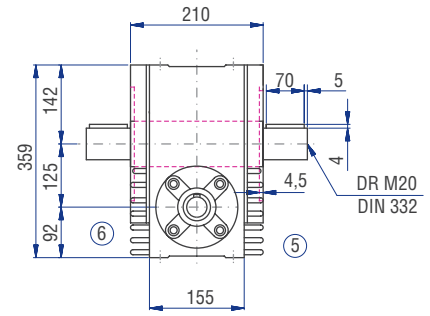
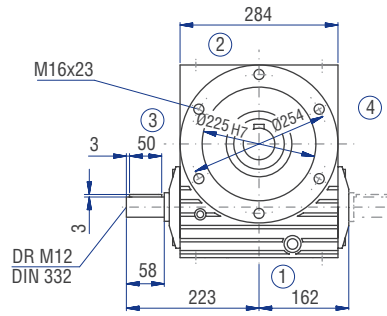
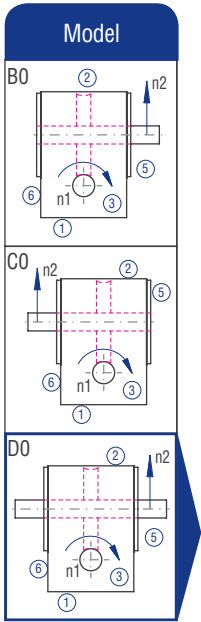

## Implementation VV

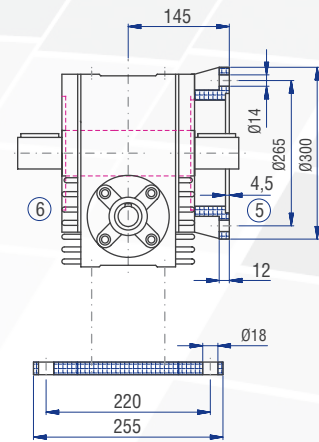
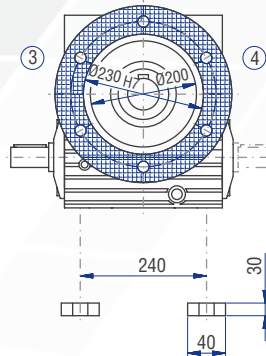
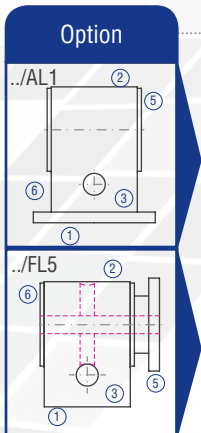
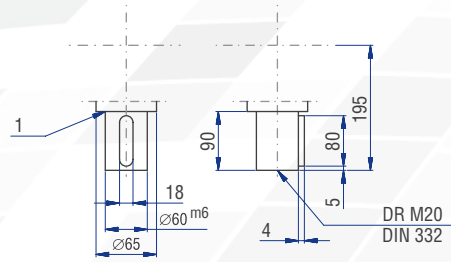



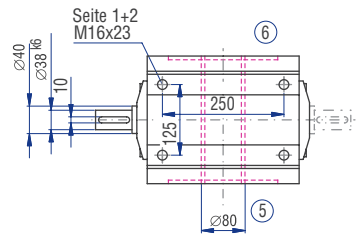
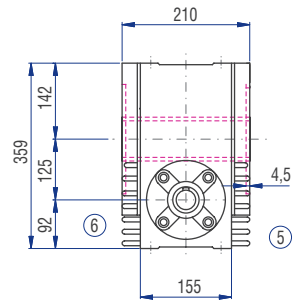
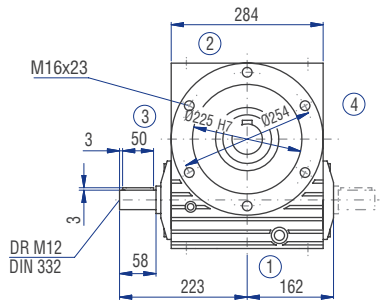

E0N0

E0K5 / E0K6

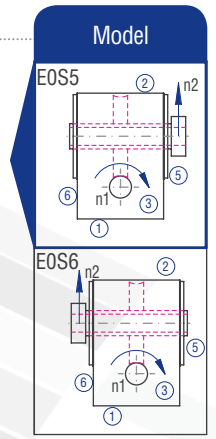
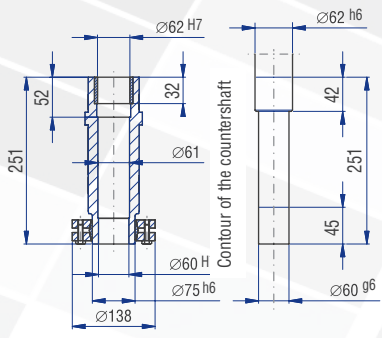
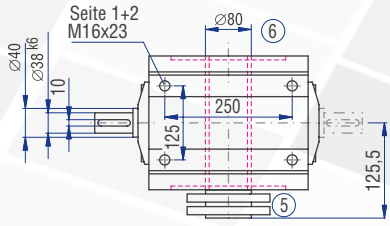
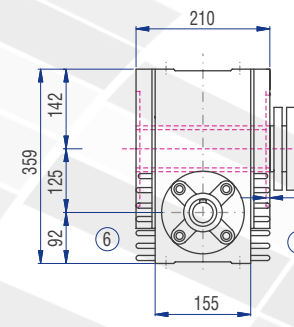
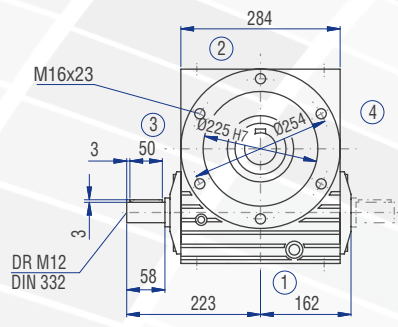
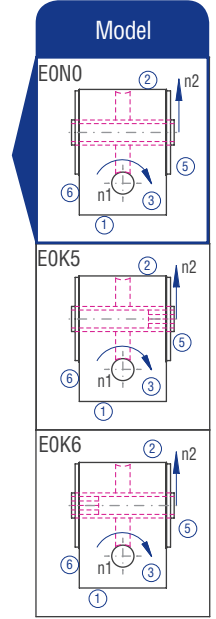
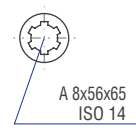
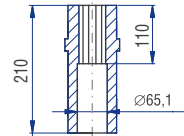
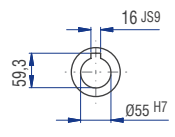

Worm  
gearboxes

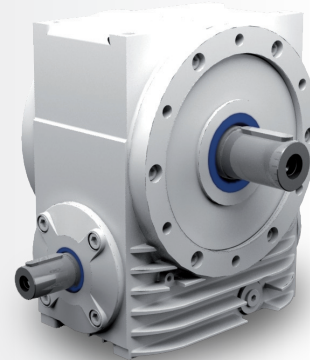

### Characteristics

Characteristic	Standard	Option
<b>Toothing</b>	Hardened and ground worm shaft / bronze worm gear	See chapter 9.2.1
<b>Gear ratio</b>	5:1 to 83:1	
<b>Housing / Flanges</b>	Grey cast iron	
<b>Threaded mounting hole</b>	On gearbox sides 1, 2 and on the flanges	See chapter 9.2.3
<b>Shaft</b>	Material 1 C45, shaft ends greased Fit with ISO j6 tolerance with parallel keyway: according to DIN 6885 Sheet 1	See chapter 4.6.2
<b>Hollow shaft</b>	Material: GGG grey cast iron; shafts greased Fit with ISO H7 tolerance with parallel keyway: according to DIN 6885 Sheet 1	See chapter 4.6.3
<b>Radial shaft seal ring</b>	NBR, form A	See chapter 4.8
<b>Ambient temperature</b>	-10°C to +90°C. The values of the performance tables are valid for 20°C	See chapter 4.9.3
<b>Circumferential backlash</b>	< 30 arcmin	See chapter 9.2.10
<b>Protection class</b>	IP 54	See chapter 4.5
<b>Corrosion protection</b>	Prime coat; layer thickness > 40 µm	See chapter 4.4
<b>Bearing life L10h</b>	more than 15,000h	See chapter 4.9.1
<b>Oil change intervals</b>	Not required if the oil temperature is kept < 90°C The lifetime of the bearings can be increased by the factor 1.5 if the oil is changed after the first 500 service hours and then every 5000 service hours.	See chapter 9.2.8
<b>Lubricant</b>	Synthetic lubricants	See chapter 9.2.8

## Performance data

i	i ist		n <sub>1</sub> [rpm]					
			3000	1500	1000	750	500	150
5:1	30:6	n <sub>2</sub> [rpm]	300.0	200.0	150.0	100.0	30.0	
		P <sub>1N</sub> [kW]	53.11	40.37	33.38	24.58	9.96	
		T <sub>2N</sub> [Nm]	1,640	1,870	2,040	2,230	2,950	
		P <sub>1NT</sub> [kW]	25.20	23.42	21.89	19.33	0.00	
		Efficiency	0.97	0.97	0.96	0.95	0.93	
7.5:1	30:4	n <sub>2</sub> [rpm]	400.0	200.0	133.0	100.0	66.0	20.0
		P <sub>1N</sub> [kW]	43.91	39.53	29.83	24.94	20.05	9.34
		T <sub>2N</sub> [Nm]	996	1,793	2,051	2,263	2,729	4,013
		P <sub>1NT</sub> [kW]	23.14	20.07	18.56	17.28	15.18	0.00
		Efficiency	0.95	0.95	0.96	0.95	0.95	0.90
10:1	40:4	n <sub>2</sub> [rpm]	300.0	150.0	100.0	75.0	50.0	15.0
		P <sub>1N</sub> [kW]	51.25	32.26	24.59	20.28	15.60	6.98
		T <sub>2N</sub> [Nm]	1,550	1,951	2,231	2,453	2,800	3,909
		P <sub>1NT</sub> [kW]	22.09	18.76	17.04	15.66	13.57	0.00
		Efficiency	0.95	0.95	0.95	0.95	0.94	0.88
13:1	54:4	n <sub>2</sub> [rpm]	230.0	115.0	76.0	57.0	38.0	11.0
		P <sub>1N</sub> [kW]	36.29	19.80	13.87	10.87	7.66	2.73
		T <sub>2N</sub> [Nm]	1,466	1,600	1,681	1,738	1,810	2,041
		P <sub>1NT</sub> [kW]	20.77	17.24	15.41	14.02	12.06	0.00
		Efficiency	0.94	0.94	0.94	0.93	0.92	0.87
15:1	30:2	n <sub>2</sub> [rpm]	200.0	100.0	66.0	50.0	33.0	10.0
		P <sub>1N</sub> [kW]	29.82	22.42	18.10	16.22	12.88	6.17
		T <sub>2N</sub> [Nm]	1,310	1,970	2,386	2,820	3,320	4,830
		P <sub>1NT</sub> [kW]	14.64	12.55	11.55	10.73	9.40	0.00
		Efficiency	0.92	0.92	0.92	0.91	0.90	0.82
20:1	40:2	n <sub>2</sub> [rpm]	150.0	75.0	50.0	37.0	25.0	7.5
		P <sub>1N</sub> [kW]	29.60	18.83	14.35	12.43	9.80	4.49
		T <sub>2N</sub> [Nm]	1,715	2,158	2,467	2,850	3,294	4,576
		P <sub>1NT</sub> [kW]	13.95	11.70	10.58	9.70	8.39	0.00
		Efficiency	0.91	0.90	0.90	0.90	0.88	0.80

	5:1	7.5:1	10:1	13:1	15:1	20:1	26:1	30:1	40:1	53:1	62:1	83:1
T <sub>2max</sub> [Nm]	4450	4450	4780	2410	4550	5050	3345	4500	5120	3700	3900	4050

## Permissible radial force F<sub>r1</sub> and axial force F<sub>a1</sub> on shaft N<sub>1</sub>

n <sub>1</sub> [rpm]	3000		1500		1000		750		500		150	
T <sub>1</sub> [Nm]	F <sub>r</sub> [N]	F <sub>a</sub> [N]	F <sub>r</sub> [N]	F <sub>a</sub> [N]	F <sub>r</sub> [N]	F <sub>a</sub> [N]	F <sub>r</sub> [N]	F <sub>a</sub> [N]	F <sub>r</sub> [N]	F <sub>a</sub> [N]	F <sub>r</sub> [N]	F <sub>a</sub> [N]
< 200	2700	1350	3100	1550	3400	1700	3700	1850	4000	2000	4350	2175
> 200	2080	1040	2390	1195	2610	1305	2850	1425	3070	1535	3340	1670

## Permissible radial force F<sub>r2</sub> and axial force F<sub>a2</sub> on shaft N<sub>2</sub>

n <sub>2</sub> [rpm]	200		125		75		50		30		10	
T <sub>2</sub> [Nm]	F <sub>r</sub> [N]	F <sub>a</sub> [N]	F <sub>r</sub> [N]	F <sub>a</sub> [N]	F <sub>r</sub> [N]	F <sub>a</sub> [N]	F <sub>r</sub> [N]	F <sub>a</sub> [N]	F <sub>r</sub> [N]	F <sub>a</sub> [N]	F <sub>r</sub> [N]	F <sub>a</sub> [N]
< 2300	5600	2800	6800	3400	7600	3800	8600	4300	10200	5100	13600	6800
> 2300	4670	2335	5670	2835	6330	3165	7170	3585	8500	4250	11300	5650

## Inertia moments/mass

Inertia moment J<sub>1</sub> related to the fast-rotating shaft (N<sub>1</sub>)

	Inertia moment [kgcm <sup>2</sup> ]											
	5:1	7.5:1	10:1	13:1	15:1	20:1	26:1	30:1	40:1	53:1	62:1	83:1
J <sub>1</sub>	157.14	118.50	78.13	56.81	95.31	65.22	52.53	89.51	61.99	51.45	67.78	53.75

The mass of the gearbox may deviate depending on the gear ratio and the type.

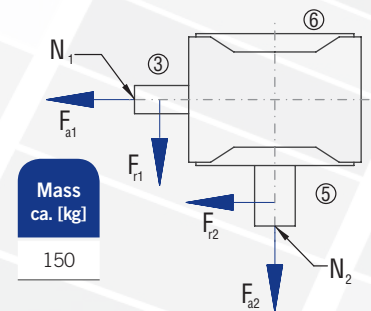

# 9.3.12 Type S 160 – Standard worm gearboxes

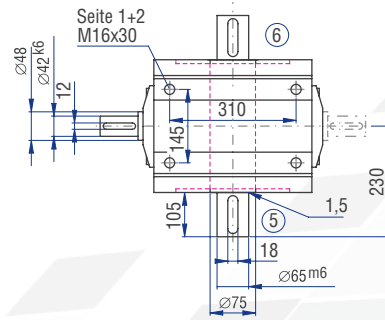
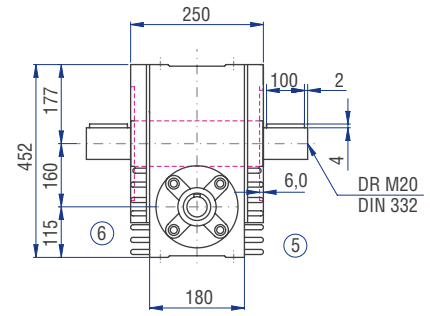
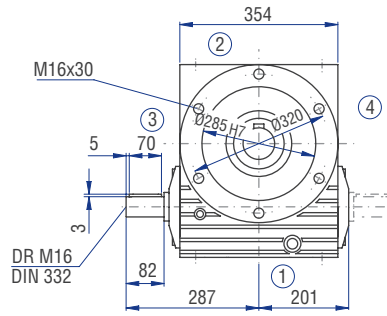
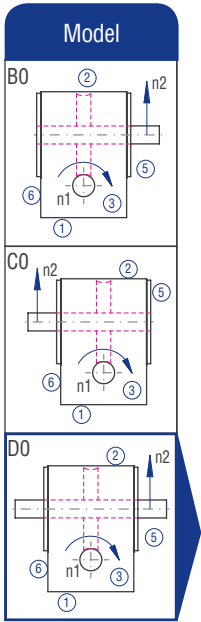

## Implementation VV

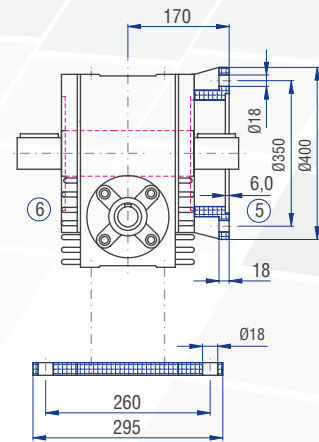
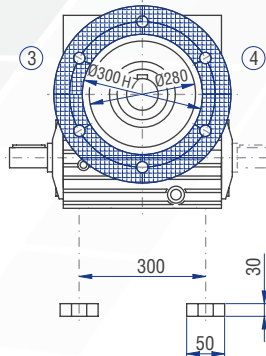
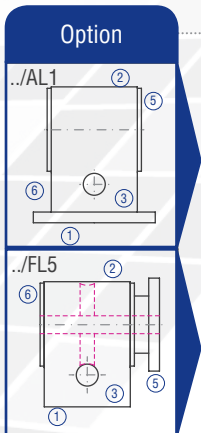
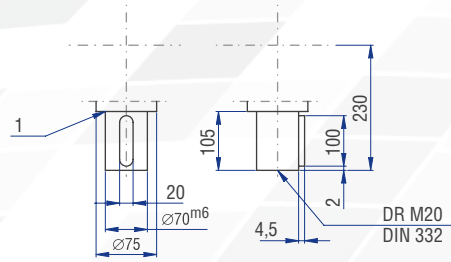

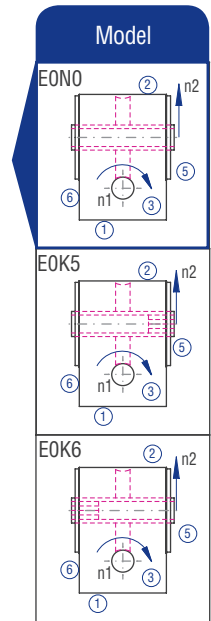
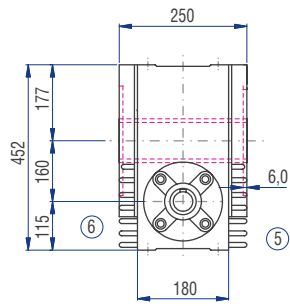
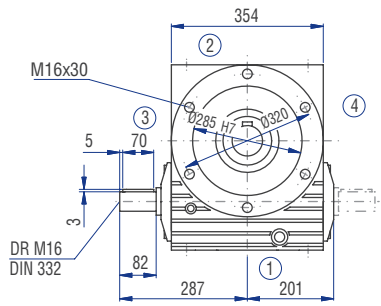

E0N0

E0K5 / E0K6

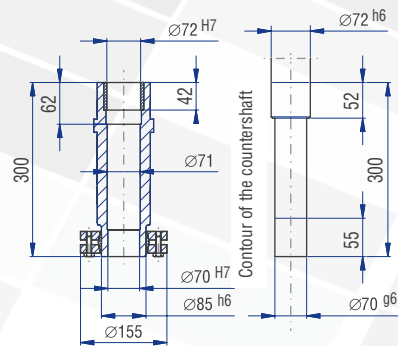
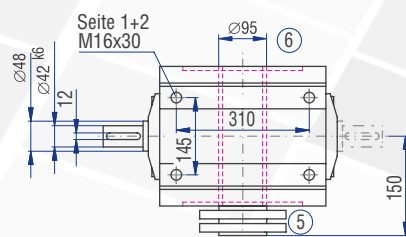
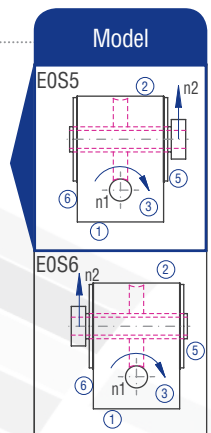
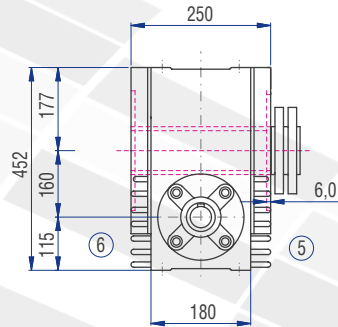
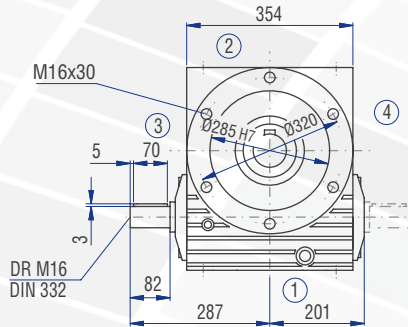
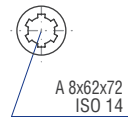
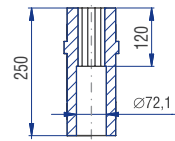
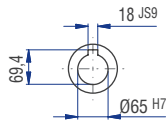
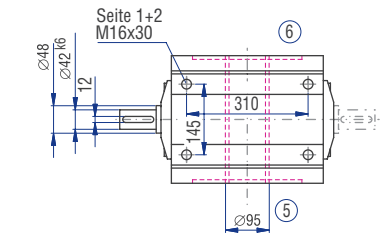

Worm  
gearboxes

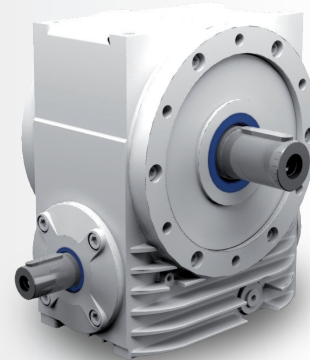

### Characteristics

Characteristic	Standard	Option
<b>Toothing</b>	Hardened and ground worm shaft / bronze worm gear	See chapter 9.2.1
<b>Gear ratio</b>	5:1 to 83:1	
<b>Housing / Flanges</b>	Grey cast iron	
<b>Threaded mounting hole</b>	On gearbox sides 1, 2 and on the flanges	See chapter 9.2.3
<b>Shaft</b>	Material 1 C45, shaft ends greased Fit with ISO j6 tolerance with parallel keyway: according to DIN 6885 Sheet 1	See chapter 4.6.2
<b>Hollow shaft</b>	Material: GGG grey cast iron; shafts greased Fit with ISO H7 tolerance with parallel keyway: according to DIN 6885 Sheet 1	See chapter 4.6.3
<b>Radial shaft seal ring</b>	NBR, form A	See chapter 4.8
<b>Ambient temperature</b>	-10°C to +90°C. The values of the performance tables are valid for 20°C	See chapter 4.9.3
<b>Circumferential backlash</b>	< 30 arcmin	See chapter 9.2.10
<b>Protection class</b>	IP 54	See chapter 4.5
<b>Corrosion protection</b>	Prime coat; layer thickness > 40 µm	See chapter 4.4
<b>Bearing life L10h</b>	more than 15,000h	See chapter 4.9.1
<b>Oil change intervals</b>	Not required if the oil temperature is kept < 90°C The lifetime of the bearings can be increased by the factor 1.5 if the oil is changed after the first 500 service hours and then every 5000 service hours.	See chapter 9.2.8
<b>Lubricant</b>	Synthetic lubricants	See chapter 9.2.8



## Performance data

i	i ist		n <sub>1</sub> [rpm]					
			3000	1500	1000	750	500	150
5:1	30:6	n <sub>2</sub> [rpm]	300.0	200.0	150.0	100.0	30.0	
		P <sub>1N</sub> [kW]	84.20	64.77	55.30	41.45	18.05	
		T <sub>2N</sub> [Nm]	260	3,000	3,380	3,800	5,400	
		P <sub>1NT</sub> [kW]	41.80	40.25	38.36	34.49	0.00	
		Efficiency	0.97	0.97	0.96	0.96	0.94	
7.5:1	30:4	n <sub>2</sub> [rpm]	200.0	133.0	100.0	66.0	20.0	
		P <sub>1N</sub> [kW]	62.59	50.68	44.55	36.26	17.32	
		T <sub>2N</sub> [Nm]	2,869	3,485	4,084	4,987	7,607	
		P <sub>1NT</sub> [kW]	33.51	32.09	30.44	27.20	0.00	
		Efficiency	0.96	0.96	0.96	0.96	0.92	
10:1	40:4	n <sub>2</sub> [rpm]	150.0	100.0	75.0	50.0	15.0	
		P <sub>1N</sub> [kW]	50.86	38.38	32.92	26.73	12.45	
		T <sub>2N</sub> [Nm]	3,076	3,519	4,024	4,851	7,134	
		P <sub>1NT</sub> [kW]	30.91	29.22	27.42	24.16	0.00	
		Efficiency	0.95	0.96	0.96	0.95	0.90	
13:1	53:4	n <sub>2</sub> [rpm]	230.0	115.0	76.0	57.0	38.0	11.0
		P <sub>1N</sub> [kW]	64.74	40.74	31.06	24.46	17.27	6.24
		T <sub>2N</sub> [Nm]	2,594	3,265	3,734	3,921	4,109	4,633
		P <sub>1NT</sub> [kW]	31.35	28.70	26.62	24.63	21.36	0.00
		Efficiency	0.95	0.95	0.95	0.94	0.88	
15:1	30:2	n <sub>2</sub> [rpm]	100.0	66.0	50.0	33.0	10.0	
		P <sub>1N</sub> [kW]	39.27	32.34	28.88	23.23	11.50	
		T <sub>2N</sub> [Nm]	3,450	4,308	5,130	6,122	9,244	
		P <sub>1NT</sub> [kW]	20.99	20.00	18.92	16.85	0.00	
		Efficiency	0.92	0.93	0.93	0.92	0.84	
20:1	40:2	n <sub>2</sub> [rpm]	150.0	75.0	50.0	37.0	25.0	7.5
		P <sub>1N</sub> [kW]	42.29	29.60	24.14	21.62	17.17	8.22
		T <sub>2N</sub> [Nm]	2,450	3,430	4,241	5,010	5,902	8,587
		P <sub>1NT</sub> [kW]	20.87	19.21	18.07	16.92	14.86	0.00
		Efficiency	0.91	0.91	0.92	0.91	0.90	0.82
26:1	53:2	n <sub>2</sub> [rpm]	115.0	57.0	38.0	28.0	19.0	5.8
		P <sub>1N</sub> [kW]	37.80	23.79	18.40	14.95	11.51	4.58
		T <sub>2N</sub> [Nm]	2,870	3,612	4,190	4,540	5,184	6,177
		P <sub>1NT</sub> [kW]	19.73	17.77	16.41	15.15	13.12	0.00
		Efficiency	0.90	0.90	0.90	0.90	0.89	0.80
30:1	30:1	n <sub>2</sub> [rpm]	50.0	33.0	25.0	16.0	5.0	
		P <sub>1N</sub> [kW]	23.74	19.73	17.62	14.33	7.43	
		T <sub>2N</sub> [Nm]	3,900	4,862	5,790	6,896	10,356	
		P <sub>1NT</sub> [kW]	12.29	11.65	11.03	9.86	0.00	
		Efficiency	0.86	0.86	0.86	0.84	0.73	
40:1	40:1	n <sub>2</sub> [rpm]	75.0	37.0	25.0	18.0	12.0	3.8
		P <sub>1N</sub> [kW]	23.93	18.04	14.66	13.14	10.56	5.58
		T <sub>2N</sub> [Nm]	2,560	3,860	4,761	5,620	6,613	9,942
		P <sub>1NT</sub> [kW]	12.58	11.27	10.56	9.89	8.75	0.00
		Efficiency	0.84	0.84	0.85	0.84	0.82	0.70
53:1	53:1	n <sub>2</sub> [rpm]	57.0	28.0	18.0	14.0	9.4	2.8
		P <sub>1N</sub> [kW]	21.71	13.99	11.19	9.40	6.79	3.09
		T <sub>2N</sub> [Nm]	3,003	3,870	4,701	5,200	5,428	6,985
		P <sub>1NT</sub> [kW]	11.96	10.48	9.65	8.93	7.81	0.00
		Efficiency	0.82	0.82	0.83	0.82	0.79	0.67
62:1	63:1	n <sub>2</sub> [rpm]	48.0	24.0	16.0	12.0	8.1	2.4
		P <sub>1N</sub> [kW]	18.60	11.56	8.81	7.36	5.84	2.99
		T <sub>2N</sub> [Nm]	2,835	3,569	4,081	4,488	5,128	6,946
		P <sub>1NT</sub> [kW]	8.90	7.77	7.28	6.85	6.14	0.00
		Efficiency	0.76	0.77	0.77	0.76	0.73	0.58
83:1	83:1	n <sub>2</sub> [rpm]	36.0	18.0	12.0	9.0	6.0	1.8
		P <sub>1N</sub> [kW]	15.43	9.58	7.31	6.06	4.21	1.61
		T <sub>2N</sub> [Nm]	3,016	3,797	4,343	4,675	4,675	4,675
		P <sub>1NT</sub> [kW]	8.61	7.38	6.80	6.34	5.62	0.00
		Efficiency	0.74	0.75	0.75	0.73	0.70	0.55

	5:1	7.5:1	10:1	13:1	15:1	20:1	26:1	30:1	40:1	53:1	62:1	83:1
T <sub>2max</sub> [Nm]	8500	9800	9277	5396	10500	10000	6790	10500	9800	7500	7000	6800

## Permissible radial force F<sub>r1</sub> and axial force F<sub>a1</sub> on shaft N<sub>1</sub>

n <sub>1</sub> [rpm]	3000		1500		1000		750		500		150	
	T <sub>1</sub> [Nm]	F <sub>r</sub> [N]	F <sub>a</sub> [N]	F <sub>r</sub> [N]	F <sub>a</sub> [N]	F <sub>r</sub> [N]	F <sub>a</sub> [N]	F <sub>r</sub> [N]	F <sub>a</sub> [N]	F <sub>r</sub> [N]	F <sub>a</sub> [N]	
< 350	3600	1800	3950	1975	4320	2160	4700	2350	5100	2550	5600	2800
> 350	2770	1385	3040	1520	3320	1660	3600	1800	3900	1950	4300	2150

## Permissible radial force F<sub>r2</sub> and axial force F<sub>a2</sub> on shaft N<sub>2</sub>

n <sub>2</sub> [rpm]	200		125		75		50		30		10	
	T <sub>2</sub> [Nm]	F <sub>r</sub> [N]	F <sub>a</sub> [N]	F <sub>r</sub> [N]	F <sub>a</sub> [N]	F <sub>r</sub> [N]	F <sub>a</sub> [N]	F <sub>r</sub> [N]	F <sub>a</sub> [N]	F <sub>r</sub> [N]	F <sub>a</sub> [N]	
< 5000	7500	3750	9300	4650	10300	5150	11500	5750	13500	6750	18000	9000
> 5000	6600	3300	8100	4050	9000	4500	10000	5000	11700	5850	15700	7850

## Inertia moments/mass

Inertia moment J<sub>1</sub> related to the fast-rotating shaft (N<sub>1</sub>)

J <sub>1</sub>	Inertia moment [kgcm <sup>2</sup> ]											
	5:1	7.5:1	10:1	13:1	15:1	20:1	26:1	30:1	40:1	53:1	62:1	83:1
J <sub>1</sub>	423.35	297.53	205.31	147.30	222.04	159.87	121.61	203.16	148.51	115.11	167.32	121.89

The mass of the gearbox may deviate depending on the gear ratio and the type.

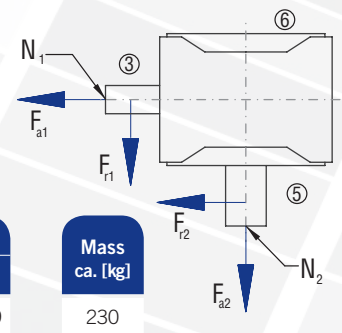

Worm  
gearboxes

# 9.3.13 Type S 200 – Standard worm gearboxes

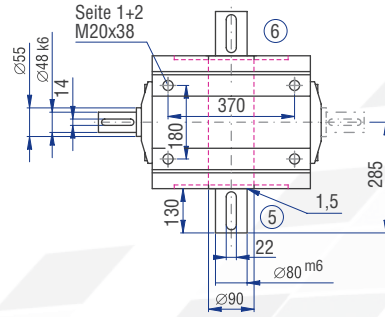
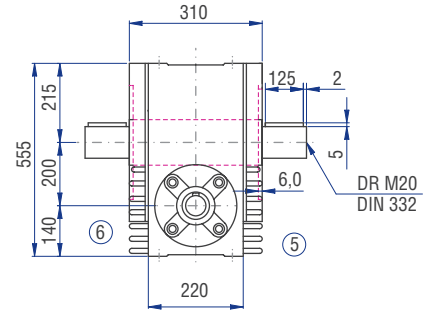
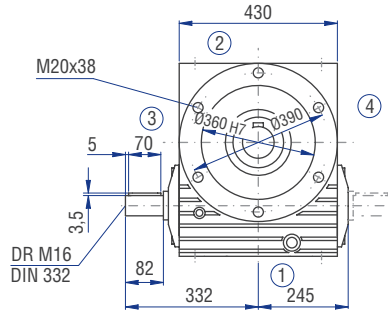
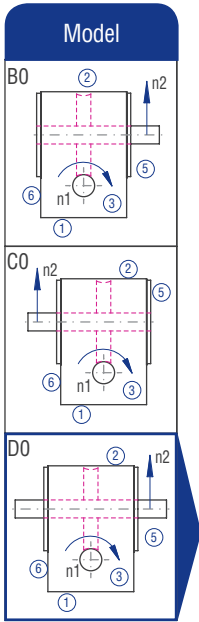

## Implementation VV

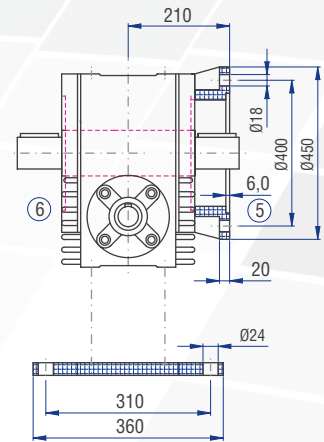
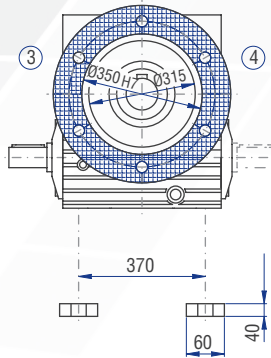
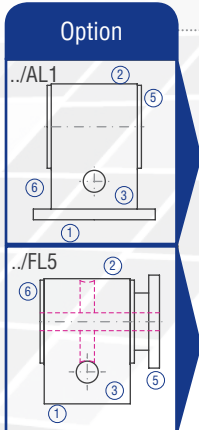
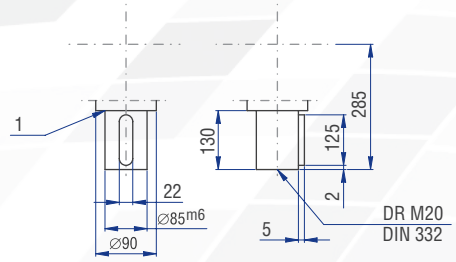

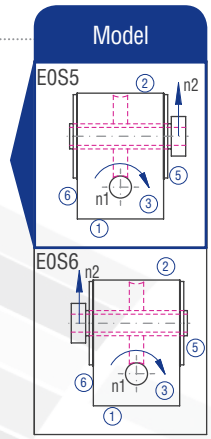
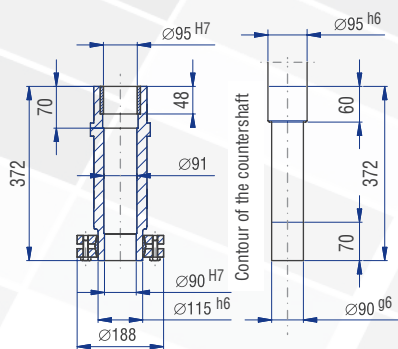
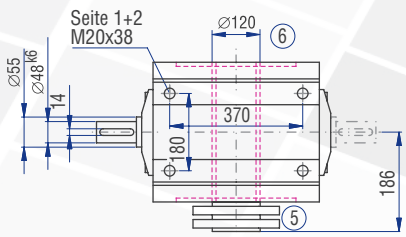
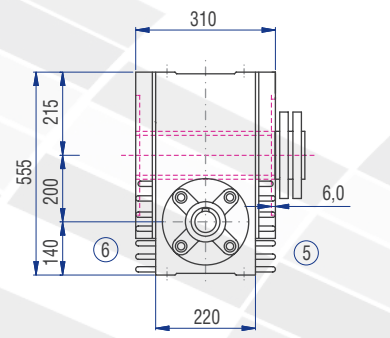
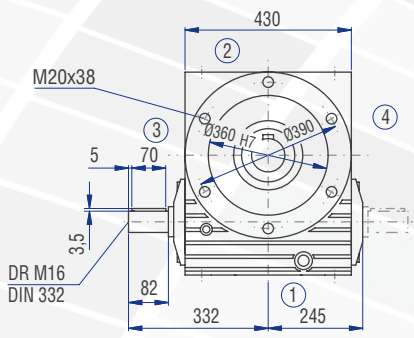
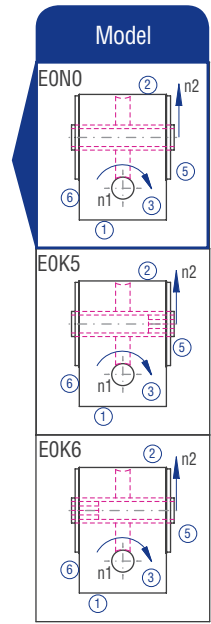
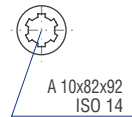
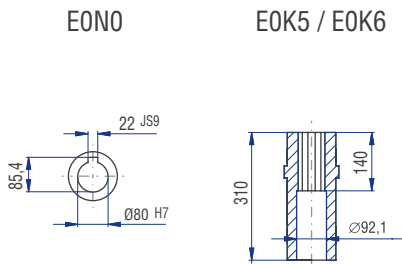
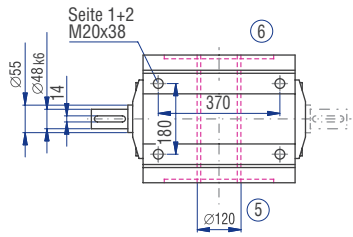
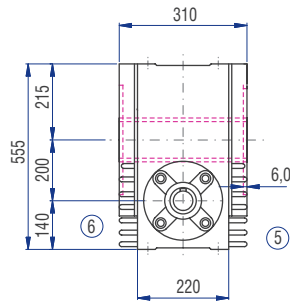
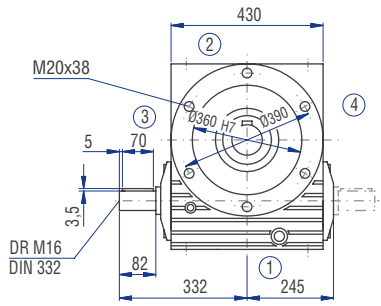

Worm  
gearboxes

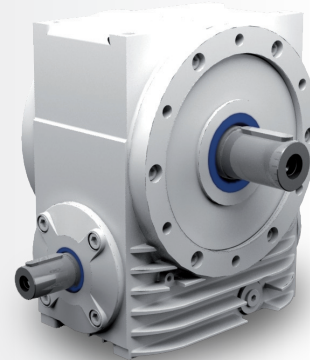

### Characteristics

Characteristic	Standard	Option
<b>Toothing</b>	Hardened and ground worm shaft / bronze worm gear	See chapter 9.2.1
<b>Gear ratio</b>	7.5:1 to 83:1	
<b>Housing / Flanges</b>	Grey cast iron	
<b>Threaded mounting hole</b>	On gearbox sides 1, 2 and on the flanges	See chapter 9.2.3
<b>Shaft</b>	Material 1 C45, shaft ends greased Fit with ISO j6 tolerance with parallel keyway: according to DIN 6885 Sheet 1	See chapter 4.6.2
<b>Hollow shaft</b>	Material: GGG grey cast iron; shafts greased Fit with ISO H7 tolerance with parallel keyway: according to DIN 6885 Sheet 1	See chapter 4.6.3
<b>Radial shaft seal ring</b>	NBR, form A	See chapter 4.8
<b>Ambient temperature</b>	-10°C to +90°C. The values of the performance tables are valid for 20°C	See chapter 4.9.3
<b>Circumferential backlash</b>	< 30 arcmin	See chapter 9.2.10
<b>Protection class</b>	IP 54	See chapter 4.5
<b>Corrosion protection</b>	Prime coat; layer thickness > 40 µm	See chapter 4.4
<b>Bearing life L10h</b>	more than 15,000h	See chapter 4.9.1
<b>Oil change intervals</b>	Not required if the oil temperature is kept < 90°C The lifetime of the bearings can be increased by the factor 1.5 if the oil is changed after the first 500 service hours and then every 5000 service hours.	See chapter 9.2.8
<b>Lubricant</b>	Synthetic lubricants	See chapter 9.2.8

## Performance data

i	i ist		n <sub>1</sub> [rpm]				
			1500	1000	750	500	150
7.5:1	31:4	n <sub>2</sub> [rpm]	200.0	133.0	100.0	66.0	20.0
		P <sub>1N</sub> [kW]	140.64	111.12	90.87	68.37	29.86
		T <sub>2N</sub> [Nm]	6,514	7,720	8,418	9,500	13,260
		P <sub>1NT</sub> [kW]	78.13	69.45	60.58	52.59	0.00
		Efficiency	0.97	0.97	0.97	0.97	0.93
10:1	40:4	n <sub>2</sub> [rpm]	150.0	100.0	75.0	50.0	15.0
		P <sub>1N</sub> [kW]	118.29	89.06	72.81	54.79	54.79
		T <sub>2N</sub> [Nm]	7,230	8,165	8,900	10,047	10,047
		P <sub>1NT</sub> [kW]	73.93	68.51	60.67	49.81	0.00
		Efficiency	0.96	0.96	0.96	0.96	0.96
13:1	52:4	n <sub>2</sub> [rpm]	115.0	76.0	57.0	38.0	11.0
		P <sub>1N</sub> [kW]	93.66	69.15	53.77	38.02	13.65
		T <sub>2N</sub> [Nm]	7,585	8,400	8,709	9,140	10,360
		P <sub>1NT</sub> [kW]	66.90	62.86	53.77	47.52	0.00
		Efficiency	0.96	0.96	0.96	0.95	0.90
15:1	31:2	n <sub>2</sub> [rpm]	100.0	66.0	50.0	33.0	10.0
		P <sub>1N</sub> [kW]	74.97	59.15	48.35	36.78	15.39
		T <sub>2N</sub> [Nm]	6,730	7,965	8,680	9,800	12,790
		P <sub>1NT</sub> [kW]	41.65	36.97	32.23	26.27	0.00
		Efficiency	0.94	0.94	0.94	0.93	0.87
20:1	40:2	n <sub>2</sub> [rpm]	75.0	50.0	37.0	25.0	7.5
		P <sub>1N</sub> [kW]	62.89	47.35	38.71	29.46	12.68
		T <sub>2N</sub> [Nm]	7,447	8,410	9,168	10,352	13,720
		P <sub>1NT</sub> [kW]	41.92	36.42	29.78	26.78	0.00
		Efficiency	0.93	0.93	0.93	0.92	0.85

i	i ist		n <sub>1</sub> [rpm]				
			1500	1000	750	500	150
26:1	52:2	n <sub>2</sub> [rpm]	57.0	38.0	28.0	19.0	5.8
		P <sub>1N</sub> [kW]	50.28	37.84	30.92	23.54	9.92
		T <sub>2N</sub> [Nm]	7,805	8,810	9,600	10,844	13,720
		P <sub>1NT</sub> [kW]	36.68	34.40	30.92	29.43	0.00
		Efficiency	0.92	0.92	0.92	0.91	0.82
30:1	31:1	n <sub>2</sub> [rpm]	50.0	33.0	25.0	16.0	5.0
		P <sub>1N</sub> [kW]	40.69	31.89	26.06	19.84	8.65
		T <sub>2N</sub> [Nm]	6,840	8,040	8,760	9,891	12,727
		P <sub>1NT</sub> [kW]	20.35	19.93	16.29	14.17	0.00
		Efficiency	0.88	0.88	0.88	0.87	0.77
40:1	40:1	n <sub>2</sub> [rpm]	37.0	25.0	18.0	12.0	3.8
		P <sub>1N</sub> [kW]	33.90	25.52	20.87	16.08	7.29
		T <sub>2N</sub> [Nm]	7,510	8,480	9,250	10,445	13,720
		P <sub>1NT</sub> [kW]	24.21	23.20	18.98	17.87	0.00
		Efficiency	0.87	0.87	0.87	0.85	0.74
53:1	52:1	n <sub>2</sub> [rpm]	28.0	18.0	14.0	9.4	2.8
		P <sub>1N</sub> [kW]	27.44	20.64	16.88	13.01	5.81
		T <sub>2N</sub> [Nm]	7,870	8,881	9,685	10,935	13,720
		P <sub>1NT</sub> [kW]	18.29	15.88	16.88	13.01	0.00
		Efficiency	0.85	0.85	0.85	0.83	0.70
62:1	61:1	n <sub>2</sub> [rpm]	24.0	16.0	12.0	8.1	2.4
		P <sub>1N</sub> [kW]	21.87	17.23	14.09	10.88	5.14
		T <sub>2N</sub> [Nm]	6,819	8,060	8,787	9,918	12,581
		P <sub>1NT</sub> [kW]	14.58	13.25	14.09	10.88	0.00
		Efficiency	0.79	0.79	0.79	0.77	0.62
83:1	83:1	n <sub>2</sub> [rpm]	18.0	12.0	9.0	6.0	1.8
		P <sub>1N</sub> [kW]	18.60	14.18	11.25	7.80	2.94
		T <sub>2N</sub> [Nm]	7,765	8,770	9,155	9,155	9,155
		P <sub>1NT</sub> [kW]	14.31	14.18	11.25	9.75	0.00
		Efficiency	0.79	0.78	0.77	0.74	0.59

	7.5:1	10:1	13:1	15:1	20:1	26:1	30:1	40:1	53:1	62:1	83:1
T <sub>2max</sub> [Nm]	13720	13720	10460	13720	13720	13720	13720	13720	13720	13720	13720

### Permissible radial force F<sub>r1</sub> and axial force F<sub>a1</sub> on shaft N<sub>1</sub>

n <sub>1</sub> [rpm]	3000		1500		1000		750		500		150	
	F <sub>r</sub> [N]	F <sub>a</sub> [N]	F <sub>r</sub> [N]	F <sub>a</sub> [N]	F <sub>r</sub> [N]	F <sub>a</sub> [N]	F <sub>r</sub> [N]	F <sub>a</sub> [N]	F <sub>r</sub> [N]	F <sub>a</sub> [N]	F <sub>r</sub> [N]	F <sub>a</sub> [N]
<b>u.r.</b>	u.r.	u.r.	u.r.	u.r.	u.r.	u.r.	u.r.	u.r.	u.r.	u.r.	u.r.	u.r.

u.r. – upon request

### Permissible radial force F<sub>r2</sub> and axial force F<sub>a2</sub> on shaft N<sub>2</sub>

n <sub>2</sub> [rpm]	200		125		75		50		30		10	
	F <sub>r</sub> [N]	F <sub>a</sub> [N]	F <sub>r</sub> [N]	F <sub>a</sub> [N]	F <sub>r</sub> [N]	F <sub>a</sub> [N]	F <sub>r</sub> [N]	F <sub>a</sub> [N]	F <sub>r</sub> [N]	F <sub>a</sub> [N]	F <sub>r</sub> [N]	F <sub>a</sub> [N]
<b>u.r.</b>	u.r.	u.r.	u.r.	u.r.	u.r.	u.r.	u.r.	u.r.	u.r.	u.r.	u.r.	u.r.

u.r. – upon request

### Inertia moments/mass

Inertia moment J<sub>1</sub> related to the fast-rotating shaft (N<sub>1</sub>)

	Inertia moment [kgcm <sup>2</sup> ]										
	7.5:1	10:1	13:1	15:1	20:1	26:1	30:1	40:1	53:1	62:1	83:1
<b>J<sub>1</sub></b>	551.70	338.70	233.60	365.20	241.20	182.20	318.60	216.80	169.30	259.50	258.30

The mass of the gearbox may deviate depending on the gear ratio and the type.

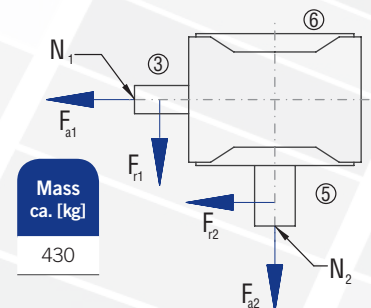

Worm gearboxes

## 9.3.14 Type S 250 – Standard worm gearboxes

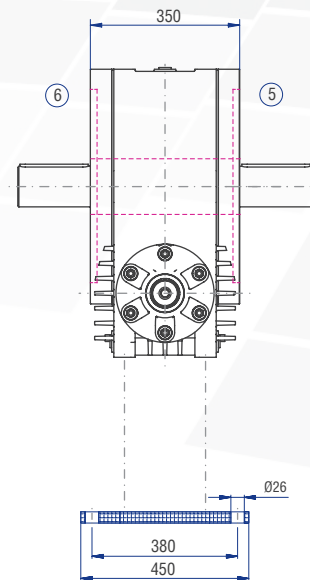
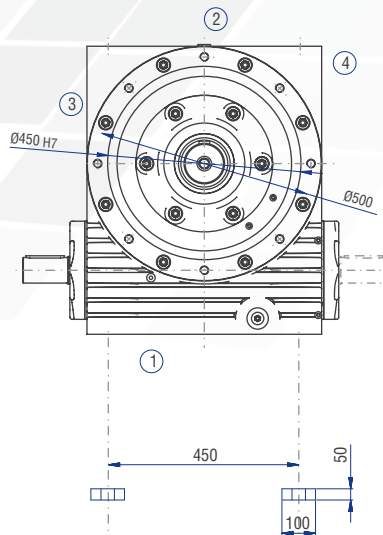
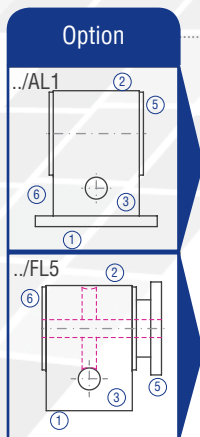
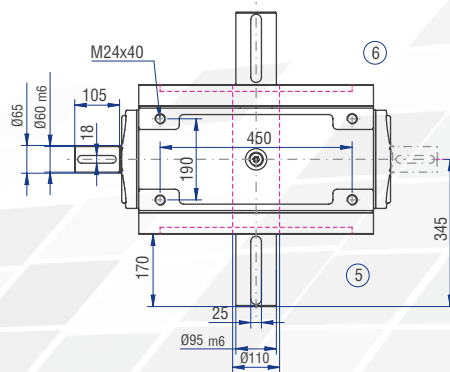
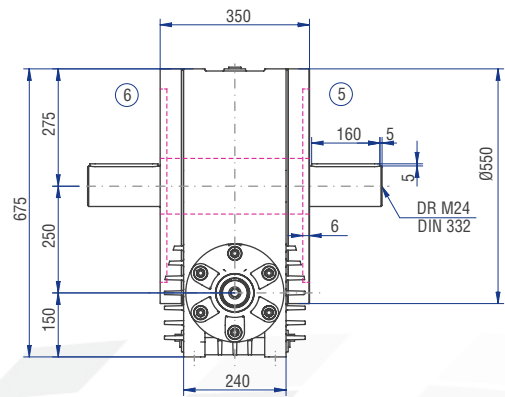
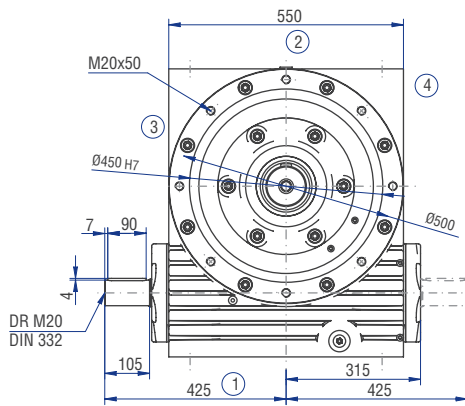
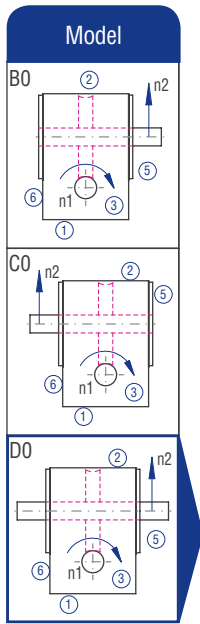



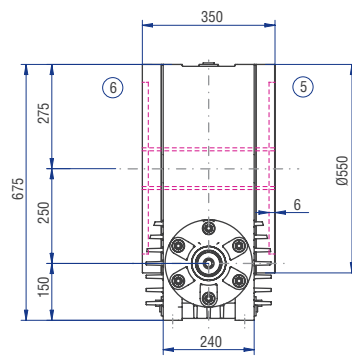
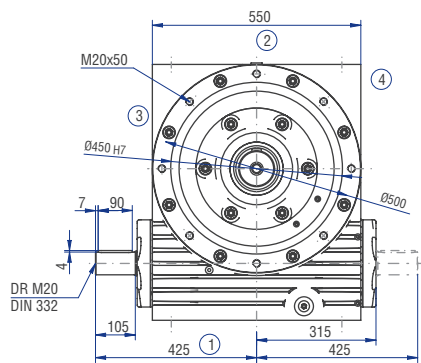

EON0

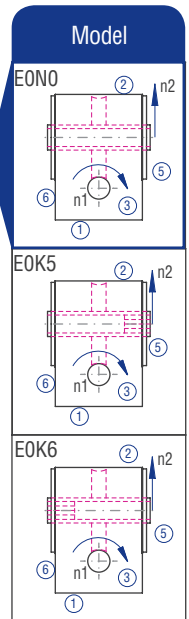
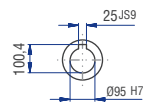
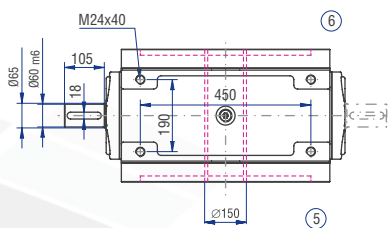

upon request

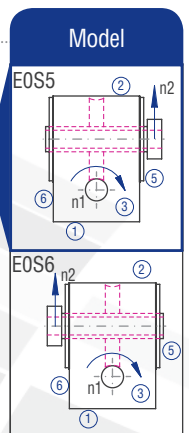

Worm  
gearboxes

# 9.4 Type SL – Type S with flange for motor mounting

## 9.4.1 Features

Nominal gear ratios:  $i = 05:1$  to  $83:1$   
 Maximum output torque: 13,720 Nm  
 9 sizes, centre-to-centre distance of 040 to 250 mm  
 Low-backlash construction < 6 angular minutes possible  
 Suitable for fitting IEC standard motors  
 Drive side with hollow-bored shaft and flange  
 Housing made of grey cast iron

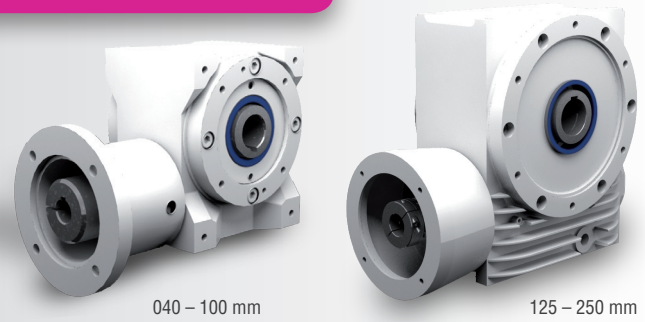

## 9.4.2 Models

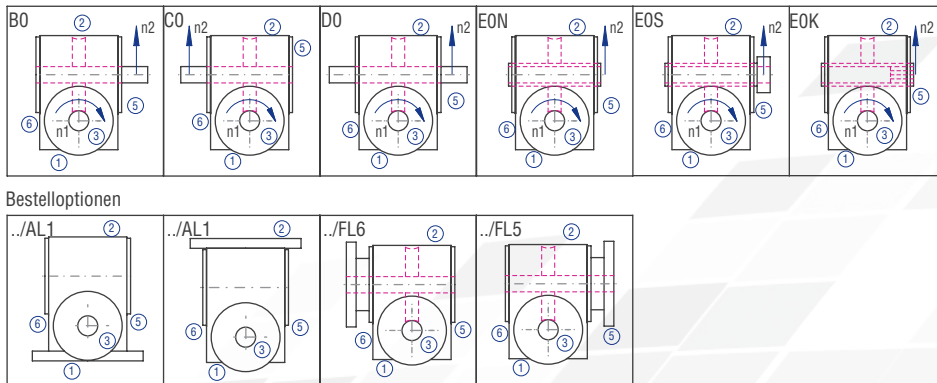

Figure 9.4.2-1; Models

## 9.4.3 Gearbox sides

The example shows the Model B0 (right picture without motor flange)

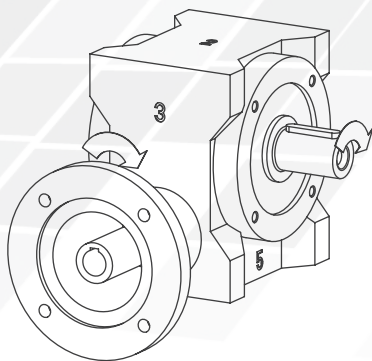

Figure 9.4.3-1; Gearbox sides

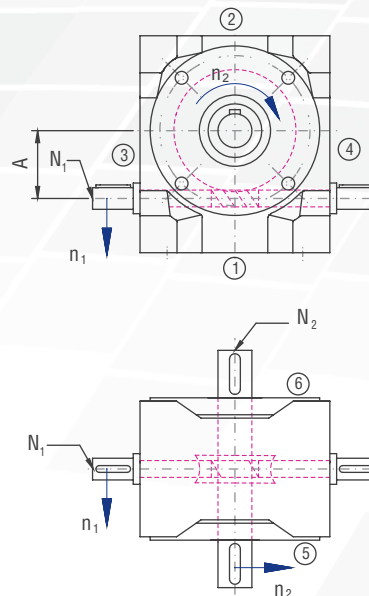

Figure 9.4.3-2; Shaft designations

## 9.4.4 Order code

The order code reflects the customer specifications. Example:

Type	Size	Gear ratio	Model	Fixing side	Installation position	Speed $n_2$	Design
SL	063	10:1	B0-	1.	1-	150	/0000
<b>Description</b>	Centre-to-centre distance A; Table 9.4.5-1	Table 9.4.5-1	Figure 9.4.2-1; Models	Side on which fixing is made; Table 9.2.3-1; Figure 4.3.1-1 Gearbox sides	Side directed downwards; Figure 4.3.1-1 Gearbox sides	Slowly rotating shaft; Table 9.4.5-1	Standard
	D120	/14x30					
	Flange diameter	Shaft diameter x length					
	Table 9.4.4-1						

## 9.4.5 Overview of performance data

Größe	n <sub>1</sub> [1/min]	5:1					7,5:1					10:1					13:1				
		n <sub>2</sub> [1/min]	P <sub>1N</sub> [kW]	T <sub>2N</sub> [Nm]	P <sub>1NT</sub> [kW]	η	n <sub>2</sub> [1/min]	P <sub>1N</sub> [kW]	T <sub>2N</sub> [Nm]	P <sub>1NT</sub> [kW]	η	n <sub>2</sub> [1/min]	P <sub>1N</sub> [kW]	T <sub>2N</sub> [Nm]	P <sub>1NT</sub> [kW]	η	n <sub>2</sub> [1/min]	P <sub>1N</sub> [kW]	T <sub>2N</sub> [Nm]	P <sub>1NT</sub> [kW]	η
040	3000	600,0	2,26	33	1,85	0,94	400,0	1,68	36	1,45	0,92	300,0	1,39	39	1,28	0,91	230,0	0,85	31	1,13	0,88
	1500	300,0	1,43	41	1,25	0,94	200,0	1,06	45	0,95	0,91	150,0	0,77	43	0,83	0,90	115,0	0,45	32	0,75	0,87
	1000	200,0	1,09	47	1,10	0,93	133,0	0,81	51	0,77	0,90	100,0	0,55	45	0,69	0,88	76,0	0,32	34	0,63	0,85
	750	150,0	0,87	49	0,90	0,87	100,0	0,65	54	0,70	0,89	75,0	0,43	47	0,63	0,87	57,0	0,26	36	0,57	0,84
	500	100,0	0,64	53	0,80	0,90	66,0	0,48	58	0,61	0,87	50,0	0,32	50	0,87	0,85	38,0	0,19	39	0,52	0,83
	150	30,0	0,25	67	0,00	0,86	20,0	0,19	73	0,00	0,82	15,0	0,13	64	0,00	0,81	11,0	0,08	50	0,00	0,80
050	3000	600,0	4,74	70	3,90	0,96	400,0	3,41	74	3,16	0,94	300,0	3,02	85	2,82	0,93	230,0	1,51	55	2,51	0,90
	1500	300,0	3,29	96	2,76	0,95	200,0	2,42	104	2,12	0,93	150,0	1,64	91	1,88	0,92	115,0	0,82	59	1,67	0,89
	1000	200,0	2,54	110	2,10	0,94	133,0	1,84	117	1,76	0,92	100,0	1,15	94	1,56	0,90	76,0	0,58	62	0,14	0,88
	750	150,0	2,08	119	2,04	0,93	100,0	1,43	120	1,57	0,91	75,0	0,96	103	1,40	0,89	57,0	0,45	64	1,27	0,87
	500	100,0	1,47	125	1,76	0,92	66,0	1,01	125	1,36	0,89	50,0	0,71	112	1,23	0,87	38,0	0,32	66	1,13	0,85
	150	30,0	0,54	145	0,00	0,88	20,0	0,40	153	0,00	0,83	15,0	0,26	130	0,00	0,82	11,0	0,12	75	0,00	0,80
063	3000	600,0	6,37	94	5,80	0,96	400,0	4,89	106	4,63	0,94	300,0	4,15	121	4,16	0,94	230,0	3,31	125	3,68	0,93
	1500	300,0	4,96	145	4,25	0,95	200,0	3,62	157	3,26	0,94	150,0	2,94	170	2,89	0,93	115,0	1,81	135	2,53	0,92
	1000	200,0	3,77	165	3,56	0,95	133,0	2,78	179	2,72	0,93	100,0	2,26	194	2,41	0,92	76,0	1,29	141	2,12	0,90
	750	150,0	3,11	180	3,15	0,94	100,0	2,37	201	2,41	0,92	75,0	1,83	207	2,15	0,91	57,0	1,00	145	1,90	0,89
	500	100,0	2,31	198	2,67	0,93	66,0	1,79	223	2,06	0,90	50,0	1,30	216	1,86	0,89	38,0	0,71	151	1,66	0,87
	150	30,0	0,91	247	0,00	0,88	20,0	0,72	280	0,00	0,84	15,0	0,51	265	0,00	0,83	11,0	0,26	170	0,00	0,82
080	3000	600,0	11,13	170	8,62	0,96	400,0	8,64	196	6,69	0,95	300,0	6,58	197	5,92	0,94	230,0	4,41	173	5,27	0,93
	1500	300,0	8,18	250	6,68	0,96	200,0	6,37	289	5,14	0,95	150,0	4,96	297	4,47	0,94	115,0	2,41	187	3,91	0,92
	1000	200,0	4,36	298	5,70	0,95	133,0	5,01	341	4,37	0,95	100,0	3,79	340	3,79	0,94	76,0	1,70	196	3,32	0,91
	750	150,0	5,55	332	5,05	0,94	100,0	4,36	391	3,88	0,94	75,0	3,15	373	3,36	0,93	57,0	1,33	202	2,96	0,90
	500	100,0	4,01	360	4,24	0,94	66,0	3,33	439	3,27	0,92	50,0	2,35	408	2,86	0,91	38,0	0,94	210	2,56	0,88
	150	30,0	1,58	448	0,00	0,89	20,0	1,39	569	0,00	0,86	15,0	0,96	513	0,00	0,84	11,0	0,34	236	0,00	0,83
100	3000	600,0	29,45	450	11,30	0,96	400,0	22,62	513	9,06	0,95	300,0	18,55	555	8,57	0,94	230,0	11,09	427	7,87	0,93
	1500	300,0	19,31	590	8,60	0,96	200,0	14,33	650	6,85	0,95	150,0	11,75	703	6,35	0,94	115,0	6,09	464	5,73	0,92
	1000	200,0	14,99	680	7,55	0,95	133,0	10,92	743	5,99	0,95	100,0	8,95	803	5,49	0,94	76,0	4,30	486	4,92	0,91
	750	150,0	12,45	745	6,87	0,94	100,0	9,10	817	5,43	0,94	75,0	7,45	882	4,95	0,93	57,0	3,37	502	4,43	0,90
	500	100,0	9,47	850	5,96	0,94	66,0	7,00	932	4,71	0,93	50,0	5,79	1006	4,30	0,91	38,0	2,37	523	3,85	0,89
	150	30,0	4,01	1150	0,00	0,90	20,0	3,03	1258	0,00	0,87	15,0	2,02	1095	0,00	0,85	11,0	0,85	586	0,00	0,83
125	3000	600,0	42,41	626	17,93	0,96	400,0	35,71	738	14,40	0,95	300,0	28,41	850	13,62	0,94	230,0	18,19	700	12,83	0,93
	1500	300,0	30,32	895	14,48	0,96	200,0	22,49	986	11,53	0,95	150,0	17,86	1069	10,68	0,94	115,0	10,02	763	9,84	0,92
	1000	200,0	23,15	1025	13,01	0,96	133,0	17,13	1127	10,31	0,95	100,0	13,61	1222	9,41	0,94	76,0	7,00	800	8,56	0,92
	750	150,0	19,34	1130	11,94	0,95	100,0	14,13	1239	9,44	0,95	75,0	11,22	1343	8,54	0,94	57,0	5,42	826	7,72	0,92
	500	100,0	14,72	1290	10,40	0,95	66,0	11,03	1436	8,20	0,94	50,0	8,62	1532	7,37	0,93	38,0	3,86	862	6,65	0,90
	150	30,0	6,29	1760	0,00	0,91	20,0	4,96	2016	0,00	0,88	15,0	3,78	2092	0,00	0,87	11,0	1,37	966	0,00	0,85
160	3000						400,0	43,91	996	23,14	0,95	300,0	51,25	1550	22,09	0,95	230,0	36,29	1466	20,77	0,94
	1500	300,0	53,11	1640	25,20	0,97	200,0	39,53	1793	20,07	0,95	150,0	32,26	1951	18,76	0,95	115,0	19,80	1600	17,24	0,94
	1000	200,0	40,37	1870	23,42	0,97	133,0	29,83	2051	18,56	0,96	100,0	24,59	2231	17,04	0,95	76,0	13,87	1681	15,41	0,94
	750	150,0	33,38	2040	21,89	0,96	100,0	24,94	2263	17,28	0,95	75,0	20,28	2453	15,66	0,95	57,0	10,87	1738	14,02	0,93
	500	100,0	24,58	2230	19,33	0,95	66,0	20,05	2729	15,18	0,95	50,0	15,60	2800	13,57	0,94	38,0	7,66	1810	12,06	0,92
	150	30,0	9,96	2950	0,00	0,93	20,0	9,34	4013	0,00	0,90	15,0	6,98	3909	0,00	0,88	11,0	2,73	2041	0,00	0,87
200	3000																230,0	64,74	2594	31,35	0,95
	1500	300,0	84,20	260	41,80	0,97	200,0	62,59	2869	33,51	0,96	150,0	50,86	3076	30,91	0,95	115,0	40,74	3265	28,70	0,95
	1000	200,0	64,77	3000	40,25	0,97	133,0	50,68	3485	32,09	0,96	100,0	38,38	3519	29,22	0,96	76,0	31,06	3734	26,62	0,95
	750	150,0	55,30	3380	38,36	0,96	100,0	44,55	4084	30,44	0,96	75,0	32,92	4024	27,42	0,96	57,0	24,46	3921	24,63	0,95
	500	100,0	41,45	3800	34,49	0,96	66,0	36,26	4987	27,20	0,96	50,0	26,73	4851	24,16	0,95	38,0	17,27	4109	21,36	0,94
	150	30,0	18,05	5400	0,00	0,94	20,0	17,32	7607	0,00	0,92	15,0	12,45	7134	0,00	0,90	11,0	6,24	4633	0,00	0,88
250	1500						200,0	140,64	6514	78,13	0,97	150,0	118,29	7230	73,93	0,96	115,0	93,66	7585	66,90	0,96
	1000						133,0	111,12	7720	69,45	0,97	100,0	89,06	8165	68,51	0,96	76,0	69,15	8400	62,86	0,96
	750						100,0	90,87	8418	60,58	0,97	75,0	72,81	8900	60,67	0,96	57,0	53,77	8709	53,77	0,96
	500						66,0	68,37	9500	52,59	0,97	50,0	54,79	10047	49,81	0,96	38,0	38,02	9140	47,52	0,95
	150						20,0	29,86	13260	0,00	0,93	15,0	54,79	10047	0,00	0,96	11,0	13,65	10360	0,00	0,90

Table 9.4.5-1

Worm  
gearboxes

# 9.4 Type SL – Type S with flange for motor mounting

Größe	n <sub>1</sub> [1/min]	15:1					20:1					26:1					30:1				
		n <sub>2</sub> [1/min]	P <sub>1N</sub> [kW]	T <sub>2N</sub> [Nm]	P <sub>1NT</sub> [kW]	η	n <sub>2</sub> [1/min]	P <sub>1N</sub> [kW]	T <sub>2N</sub> [Nm]	P <sub>1NT</sub> [kW]	η	n <sub>2</sub> [1/min]	P <sub>1N</sub> [kW]	T <sub>2N</sub> [Nm]	P <sub>1NT</sub> [kW]	η	n <sub>2</sub> [1/min]	P <sub>1N</sub> [kW]	T <sub>2N</sub> [Nm]	P <sub>1NT</sub> [kW]	η
040	3000	200,0	0,93	37	0,85	0,86	150,0	0,82	43	0,77	0,84	115,0	0,55	36	0,68	0,80	100,0	0,53	36	0,51	0,75
	1500	100,0	0,60	48	0,55	0,84	75,0	0,49	50	0,49	0,82	57,0	0,30	38	0,44	0,78	50,0	0,37	50	0,33	0,73
	1000	66,0	0,48	55	0,46	0,82	50,0	0,36	53	0,42	0,80	38,0	0,21	40	0,38	0,76	33,0	0,29	57	0,28	0,70
	750	50,0	0,39	58	0,41	0,81	37,0	0,28	55	0,38	0,78	28,0	0,17	42	0,34	0,75	25,0	0,24	60	0,26	0,68
	500	33,0	0,29	63	0,36	0,78	25,0	0,21	58	0,34	0,76	19,0	0,12	45	0,31	0,73	16,0	0,18	65	0,23	0,64
	150	10,0	0,12	79	0,00	0,72	7,5	0,09	75	0,00	0,71	5,8	0,05	59	0,00	0,69	5,0	0,08	82	0,00	0,57
050	3000	200,0	1,82	74	1,91	0,88	150,0	1,54	81	1,70	0,87	115,0	1,04	71	1,51	0,84	100,0	1,12	82	1,14	0,79
	1500	100,0	1,32	106	1,27	0,87	75,0	1,03	106	1,12	0,85	57,0	0,58	76	1,00	0,81	50,0	0,79	113	0,76	0,77
	1000	66,0	1,02	120	1,05	0,85	50,0	0,73	110	0,93	0,83	38,0	0,42	80	0,84	0,79	33,0	0,59	121	0,63	0,74
	750	50,0	0,84	131	0,94	0,84	37,0	0,63	123	0,84	0,81	28,0	0,32	82	0,76	0,78	25,0	0,54	144	0,06	0,72
	500	33,0	0,65	145	0,82	0,81	25,0	0,47	133	0,74	0,78	19,0	0,24	86	0,68	0,75	16,0	0,42	157	0,50	0,68
	150	10,0	0,26	179	0,00	0,74	7,5	0,18	158	0,00	0,72	5,8	0,09	98	0,00	0,70	5,0	0,18	201	0,00	0,59
063	3000	200,0	3,12	128	2,80	0,89	150,0	2,95	161	2,52	0,88	115,0	1,89	132	2,21	0,86	100,0	1,94	143	1,66	0,80
	1500	100,0	2,23	183	1,95	0,00	75,0	1,70	186	1,73	0,88	57,0	1,25	173	1,52	0,85	50,0	1,38	204	1,15	0,80
	1000	66,0	1,77	213	1,62	0,00	50,0	1,32	212	1,44	0,86	38,0	0,90	181	1,27	0,83	33,0	1,11	237	0,97	0,77
	750	50,0	1,51	240	1,44	0,86	37,0	1,14	237	1,29	0,84	28,0	0,71	187	1,14	0,81	25,0	0,97	268	0,86	0,75
	500	33,0	1,16	266	1,23	0,83	25,0	0,86	259	1,12	0,81	19,0	0,51	195	1,01	0,78	16,0	0,75	296	0,75	0,71
	150	10,0	0,48	333	0,00	0,75	7,5	0,34	310	0,00	0,74	5,8	0,19	222	0,00	0,71	5,0	0,36	403	0,00	0,61
080	3000	200,0	5,61	241	4,08	0,90	150,0	4,24	240	3,59	0,89	115,0	2,83	210	3,19	0,88	100,0	3,47	272	2,41	0,82
	1500	100,0	4,10	352	3,09	0,90	75,0	3,04	344	2,67	0,89	57,0	1,67	245	2,34	0,87	50,0	2,52	395	1,81	0,82
	1000	66,0	3,26	415	2,62	0,89	50,0	2,37	399	2,26	0,88	38,0	1,19	256	1,99	0,85	33,0	2,03	456	1,54	0,80
	750	50,0	2,81	473	2,32	0,88	37,0	2,05	450	2,01	0,86	28,0	0,94	264	1,78	0,83	25,0	1,78	530	1,38	0,78
	500	33,0	2,18	530	1,97	0,85	25,0	1,57	498	1,72	0,83	19,0	0,68	275	1,55	0,80	16,0	1,38	593	1,18	0,75
	150	10,0	0,93	681	0,00	0,77	7,5	0,64	615	0,00	0,75	5,8	0,25	312	0,00	0,73	5,0	0,63	760	0,00	0,63
100	3000	200,0	13,12	564	5,76	0,90	150,0	10,84	614	5,44	0,89	115,0	7,63	556	4,94	0,88	100,0	7,53	590	3,50	0,82
	1500	100,0	8,32	715	4,31	0,90	75,0	6,87	778	3,99	0,89	57,0	4,20	605	3,57	0,87	50,0	4,78	748	2,60	0,82
	1000	66,0	6,41	817	3,75	0,89	50,0	5,28	888	3,44	0,88	38,0	3,00	634	3,06	0,85	33,0	3,60	825	2,27	0,80
	750	50,0	5,34	898	3,40	0,88	37,0	4,45	975	3,10	0,86	28,0	2,38	655	2,75	0,83	25,0	3,19	950	2,06	0,78
	500	33,0	4,16	1025	2,95	0,86	25,0	3,47	1112	2,69	0,84	19,0	1,72	683	2,40	0,80	16,0	2,51	1080	1,81	0,75
	150	10,0	1,88	1386	0,00	0,77	7,5	1,49	1441	0,00	0,76	5,8	0,64	773	0,00	0,73	5,0	1,18	1437	0,00	0,64
125	3000	200,0	20,06	862	9,13	0,90	150,0	16,59	940	8,61	0,89	115,0	12,76	929	8,09	0,88	100,0	11,76	901	5,50	0,83
	1500	100,0	12,61	1084	7,24	0,90	75,0	10,44	1183	6,68	0,89	57,0	7,03	1012	6,14	0,87	50,0	7,49	1134	4,31	0,82
	1000	66,0	10,01	1290	6,44	0,90	50,0	7,95	1352	5,86	0,89	38,0	4,97	1062	5,32	0,86	33,0	6,38	1448	3,83	0,82
	750	50,0	8,88	1510	5,88	0,89	37,0	6,74	1510	5,31	0,88	28,0	3,90	1097	4,80	0,85	25,0	5,65	1690	3,51	0,81
	500	33,0	6,91	1743	5,10	0,88	25,0	5,23	1717	4,58	0,86	19,0	2,78	1146	4,14	0,83	16,0	4,52	1952	3,08	0,78
	150	10,0	3,21	2423	0,00	0,79	7,5	2,33	2310	0,00	0,78	5,8	1,04	1294	0,00	0,75	5,0	1,86	2270	0,00	0,66
160	3000	200,0	29,82	1310	14,64	0,92	150,0	29,60	1715	13,95	0,91	115,0	23,70	1813	13,07	0,89	100,0	20,44	1640	8,79	0,84
	1500	100,0	22,42	1970	12,55	0,92	75,0	18,83	2158	11,70	0,90	57,0	13,88	2124	10,71	0,89	50,0	13,53	2170	7,39	0,84
	1000	66,0	18,10	2386	11,55	0,92	50,0	14,35	2467	10,58	0,90	38,0	9,83	2231	9,53	0,88	33,0	11,13	2678	6,79	0,84
	750	50,0	16,22	2820	10,73	0,91	37,0	12,43	2850	9,70	0,90	28,0	7,63	2307	8,66	0,88	25,0	9,85	3160	6,31	0,84
	500	33,0	12,88	3320	9,40	0,90	25,0	9,80	3294	8,39	0,88	19,0	5,44	2413	7,45	0,86	16,0	8,02	3720	5,57	0,81
	150	10,0	6,17	4830	0,00	0,82	7,5	4,49	4576	0,00	0,80	5,8	2,06	2727	0,00	0,77	5,0	3,41	4500	0,00	0,69
200	3000	100,0	39,27	3450	20,99	0,92	75,0	29,60	3430	19,21	0,91	57,0	23,79	3612	17,77	0,90	50,0	23,74	3900	12,29	0,86
	1500	66,0	32,34	4308	20,00	0,93	50,0	24,14	4241	18,07	0,92	38,0	18,40	4190	16,41	0,90	33,0	19,73	4862	11,65	0,86
	1000	50,0	28,88	5130	18,92	0,93	37,0	21,62	5010	16,92	0,91	28,0	14,95	4540	15,15	0,90	25,0	17,62	5790	11,03	0,86
	750	33,0	23,23	6122	16,85	0,92	25,0	17,17	5902	14,86	0,90	19,0	11,51	5184	13,12	0,89	16,0	14,33	6896	9,86	0,84
	500	10,0	11,50	9244	0,00	0,84	7,5	8,22	8587	0,00	0,82	5,8	4,58	6177	0,00	0,80	5,0	7,43	10356	0,00	0,73
	150	3,0	18,05	5400	0,00	0,94	20,0	17,32	7607	0,00	0,92	15,0	12,45	7134	0,00	0,90	11,0	6,24	4633	0,00	0,88
250	1500	100,0	74,97	6730	41,65	0,94	75,0	62,89	7447	41,92	0,93	57,0	50,28	7805	36,68	0,92	50,0	40,69	6840	20,35	0,88
	1000	66,0	59,15	7965	36,97	0,94	50,0	47,35	8410	36,42	0,93	38,0	37,84	8810	34,40	0,92	33,0	31,89	8040	19,93	0,88
	750	50,0	48,35	8680	32,23	0,94	37,0	38,71	9168	29,78	0,93	28,0	30,92	9600	30,92	0,92	25,0	26,06	8760	16,29	0,88
	500	33,0	36,78	9800	26,27	0,93	25,0	29,46	10352	26,78	0,92	19,0	23,54	10844	29,43	0,91	16,0	19,84	9891	14,17	0,87
	150	10,0	15,39	12790	0,00	0,87	7,5	12,68	13720	0,00	0,85	5,8	9,92	13720	0,00	0,82	5,0	8,65	12727	0,00	0,77

Table 9.4.5-1

Größe	n <sub>1</sub> [1/min]	40:1					53:1					62:1					83:1				
		n <sub>2</sub> [1/min]	P <sub>1N</sub> [kW]	T <sub>2N</sub> [Nm]	P <sub>1NT</sub> [kW]	η	n <sub>2</sub> [1/min]	P <sub>1N</sub> [kW]	T <sub>2N</sub> [Nm]	P <sub>1NT</sub> [kW]	η	n <sub>2</sub> [1/min]	P <sub>1N</sub> [kW]	T <sub>2N</sub> [Nm]	P <sub>1NT</sub> [kW]	η	n <sub>2</sub> [1/min]	P <sub>1N</sub> [kW]	T <sub>2N</sub> [Nm]	P <sub>1NT</sub> [kW]	η
040	3000	75,0	0,48	44	0,46	0,72	57,0	0,39	44	0,42	0,68	48,0	0,36	45	0,35	0,63	36,0	0,25	36	0,32	0,56
	1500	37,0	0,32	56	0,30	0,70	28,0	0,21	46	0,28	0,65	24,0	0,20	48	0,23	0,59	18,0	0,14	37	0,21	0,52
	1000	25,0	0,25	63	0,25	0,67	18,0	0,15	48	0,24	0,63	16,0	0,15	51	0,20	0,56	12,0	0,10	38	0,18	0,50
	750	18,0	0,20	66	0,23	0,65	14,0	0,13	51	0,22	0,61	12,0	0,12	53	0,18	0,54	9,0	0,08	38	0,17	0,48
	500	12,0	0,15	71	0,21	0,62	9,4	0,09	55	0,20	0,59	8,1	0,09	56	0,16	0,51	6,0	0,05	38	0,15	0,46
	150	3,8	0,07	91	0,00	0,56	2,8	0,04	72	0,00	0,55	2,4	0,03	57	0,00	0,45	1,8	0,02	38	0,00	0,42
050	3000	75,0	0,87	80	1,02	0,76	57,0	0,65	77	0,92	0,73	48,0	0,61	81	0,75	0,67	36,0	0,39	59	0,70	0,58
	1500	37,0	0,65	118	0,68	0,75	28,0	0,38	85	0,62	0,69	24,0	0,42	105	0,50	0,64	18,0	0,21	63	0,47	0,56
	1000	25,0	0,52	134	0,57	0,71	18,0	0,27	88	0,52	0,67	16,0	0,31	109	0,43	0,60	12,0	0,15	64	0,41	0,54
	750	18,0	0,41	137	0,52	0,69	14,0	0,22	91	0,48	0,64	12,0	0,25	112	0,39	0,57	9,0	0,12	66	0,37	0,52
	500	12,0	0,31	147	0,46	0,65	9,4	0,16	95	0,43	0,61	8,1	0,18	113	0,36	0,53	6,0	0,09	69	0,34	0,49
	150	3,8	0,13	183	0,00	0,57	2,8	0,06	110	0,00	0,55	2,4	0,06	113	0,00	0,45	1,8	0,03	75	0,00	0,44
063	3000	75,0	1,54	149	1,50	0,78	57,0	1,16	143	1,34	0,76	48,0	0,82	110	1,10	0,69	36,0	0,75	129	0,99	0,66
	1500	37,0	1,08	207	1,04	0,77	28,0	0,80	191	0,96	0,74	24,0	0,66	175	0,76	0,68	18,0	0,46	152	0,69	0,63
	1000	25,0	0,85	237	0,87	0,75	18,0	0,58	200	0,78	0,71	16,0	0,53	202	0,65	0,65	12,0	0,33	152	0,59	0,59
	750	18,0	0,74	264	0,78	0,72	14,0	0,47	207	0,71	0,68	12,0	0,46	221	0,59	0,62	9,0	0,26	152	0,54	0,56
	500	12,0	0,57	288	0,69	0,68	9,4	0,34	217	0,63	0,65	8,1	0,34	226	0,52	0,57	6,0	0,19	152	0,49	0,52
	150	3,8	0,24	348	0,00	0,59	2,8	0,14	248	0,00	0,56	2,4	0,12	226	0,00	0,47	1,8	0,07	152	0,00	0,44
080	3000	75,0	2,62	267	2,14	0,80	57,0	1,78	234	1,93	0,78	48,0	1,40	194	1,55	0,70	36,0	1,10	196	1,43	0,68
	1500	37,0	1,87	381	1,58	0,80	28,0	1,04	271	1,41	0,77	24,0	1,01	279	1,15	0,70	18,0	0,90	304	1,04	0,65
	1000	25,0	1,49	443	1,35	0,78	18,0	0,76	284	1,20	0,74	16,0	0,81	325	0,98	0,68	12,0	0,64	304	0,90	0,61
	750	18,0	1,31	501	1,21	0,75	14,0	0,61	294	1,09	0,71	12,0	0,69	352	0,89	0,65	9,0	0,49	304	0,82	0,59
	500	12,0	1,02	553	1,05	0,71	9,4	0,45	308	0,96	0,68	8,1	0,54	393	0,78	0,61	6,0	0,35	304	0,73	0,55
	150	3,8	0,40	625	0,00	0,61	2,8	0,18	352	0,00	0,58	2,4	0,23	448	0,00	0,49	1,8	0,13	304	0,00	0,46
100	3000	75,0	6,33	645	3,32	0,80	57,0	4,76	615	3,04	0,78	48,0	4,59	645	2,39	0,70	36,0	3,33	591	2,24	0,68
	1500	37,0	4,01	817	2,42	0,80	28,0	2,63	670	2,19	0,77	24,0	2,91	817	1,74	0,70	18,0	1,74	599	1,61	0,66
	1000	25,0	3,13	933	2,09	0,78	18,0	1,92	704	1,88	0,74	16,0	2,17	886	1,52	0,68	12,0	1,23	599	1,40	0,62
	750	18,0	2,65	1025	1,90	0,76	14,0	1,53	728	1,71	0,72	12,0	1,70	886	1,39	0,65	9,0	0,94	599	1,28	0,61
	500	12,0	2,13	1169	1,67	0,72	9,4	1,11	762	1,51	0,69	8,1	1,21	886	1,24	0,61	6,0	0,67	599	1,15	0,57
	150	3,8	1,00	1581	0,00	0,62	2,8	0,45	870	0,00	0,59	2,4	0,44	886	0,00	0,50	1,8	0,24	599	0,00	0,47
125	3000	75,0	9,57	987	5,22	0,81	57,0	7,93	1037	4,93	0,79	48,0	6,86	988	3,75	0,73	36,0	5,72	1043	3,55	0,69
	1500	37,0	6,10	1242	4,00	0,80	28,0	4,44	1132	3,71	0,77	24,0	4,37	1243	2,86	0,72	18,0	3,30	1167	2,66	0,67
	1000	25,0	4,81	1470	3,52	0,80	18,0	3,15	1189	3,23	0,76	16,0	3,38	1421	2,52	0,71	12,0	2,23	1167	2,33	0,66
	750	18,0	4,25	1690	3,20	0,78	14,0	2,48	1230	2,93	0,75	12,0	2,87	1562	2,32	0,69	9,0	1,73	1167	2,13	0,64
	500	12,0	3,35	1922	2,79	0,75	9,4	1,83	1289	2,56	0,71	8,1	2,25	1731	2,05	0,65	6,0	1,23	1167	1,89	0,60
	150	3,8	1,42	2310	0,00	0,64	2,8	0,73	1470	0,00	0,61	2,4	0,84	1731	0,00	0,52	1,8	0,46	1167	0,00	0,48
160	3000	75,0	17,04	1801	8,41	0,83	57,0	13,62	1896	7,93	0,81	48,0	11,97	1800	6,00	0,75	36,0	9,76	1906	5,72	0,73
	1500	37,0	10,73	2267	6,92	0,83	28,0	8,52	2372	6,39	0,81	24,0	7,53	2266	4,87	0,75	18,0	6,10	2347	4,55	0,72
	1000	25,0	8,73	2735	6,25	0,82	18,0	6,05	2494	5,69	0,80	16,0	5,82	2591	4,42	0,74	12,0	4,18	2347	4,07	0,70
	750	18,0	7,73	3190	5,76	0,81	14,0	4,81	2582	5,19	0,78	12,0	4,86	2848	4,09	0,73	9,0	3,18	2347	3,74	0,69
	500	12,0	6,11	3688	5,02	0,79	9,4	3,50	2708	4,52	0,75	8,1	3,83	3225	3,63	0,70	6,0	2,25	2347	3,31	0,65
	150	3,8	2,90	4952	0,00	0,67	2,8	1,40	3091	0,00	0,64	2,4	1,61	3552	0,00	0,55	1,8	0,74	2347	0,00	0,59
200	3000	75,0	23,93	2560	12,58	0,84	57,0	21,71	3003	11,96	0,82	48,0	18,60	2835	8,90	0,76	36,0	15,43	3016	8,61	0,74
	1500	37,0	18,04	3860	11,27	0,84	28,0	13,99	3870	10,48	0,82	24,0	11,56	3569	7,77	0,77	18,0	9,58	3797	7,38	0,75
	1000	25,0	14,66	4761	10,56	0,85	18,0	11,19	4701	9,65	0,83	16,0	8,81	4081	7,28	0,77	12,0	7,31	4343	6,80	0,75
	750	18,0	13,14	5620	9,89	0,84	14,0	9,40	5200	8,93	0,82	12,0	7,36	4488	6,85	0,76	9,0	6,06	4675	6,34	0,73
	500	12,0	10,56	6613	8,75	0,82	9,4	6,79	5428	7,81	0,79	8,1	5,84	5128	6,14	0,73	6,0	4,21	4675	5,62	0,70
	150	3,8	5,58	9942	0,00	0,70	2,8	3,09	6985	0,00	0,67	2,4	2,99	6946	0,00	0,58	1,8	1,61	4675	0,00	0,55
250	1500	37,0	33,90	7510	24,21	0,87	28,0	27,44	7870	18,29	0,85	24,0	21,87	6819	14,58	0,79	18,0	18,60	7765	14,31	0,79
	1000	25,0	25,52	8480	23,20	0,87	18,0	20,64	8881	15,88	0,85	16,0	17,23	8060	13,25	0,79	12,0	14,18	8770	14,18	0,78
	750	18,0	20,87	9250	18,98	0,87	14,0	16,88	9685	16,88	0,85	12,0	14,09	8787	14,09	0,79	9,0	11,25	9155	11,25	0,77
	500	12,0	16,08	10445	17,87	0,85	9,4	13,01	10935	13,01	0,83	8,1	10,88	9918	10,88	0,77	6,0	7,80	9155	9,75	0,74
	150	3,8	7,29	13720	0,00	0,74	2,8	5,81	13720	0,00	0,70	2,4	5,14	12581	0,00	0,62	1,8	2,94	9155	0,00	0,59

Table 9.4.5-1

## 9.4.6 Type SL 040 – Type S with flange for motor mounting

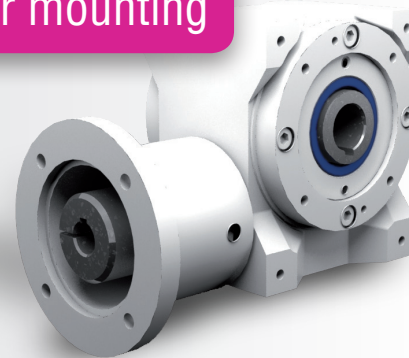

### Characteristics

Characteristic	Standard	Option
<b>Toothing</b>	Hardened and ground worm shaft / bronze worm gear	See chapter 9.2.1
<b>Gear ratio</b>	5:1 to 83:1	
<b>Housing / Flanges</b>	Grey cast iron	
<b>Threaded mounting hole</b>	On gearbox side 1 and on the flanges	See chapter 9.2.3
<b>Shaft</b>	Material 1 C45, shaft ends greased Fit with ISO j6 tolerance with parallel keyway: according to DIN 6885 Sheet 1	See chapter 4.6.2
<b>Hollow shaft</b>	Material 1 C45, shafts greased Fit with ISO H7 tolerance with parallel keyway: according to DIN 6885 Sheet 1	See chapter 4.6.3
<b>Radial shaft seal ring</b>	NBR, form A	See chapter 4.8
<b>Ambient temperature</b>	-10°C to +90°C. The values of the performance tables are valid for 20°C	See chapter 4.9.3
<b>Circumferential backlash</b>	< 30 arcmin	See chapter 9.2.10
<b>Protection class</b>	IP 54	See chapter 4.5
<b>Corrosion protection</b>	Prime coat; layer thickness > 40 µm	See chapter 4.4.1
<b>Bearing life L10h</b>	more than 15,000h	See chapter 4.9.1
<b>Oil change intervals</b>	Not required if the oil temperature is kept below 90°C. The lifetime of the bearings can be increased by the factor 1.5 if the oil is changed after the first 500 service hours and then every 5000 service hours.	See chapter 9.2.8
<b>Lubricants</b>	Synthetic lubricants	See chapter 9.2.8
<b>Flange</b>	Suited for the mounting of IEC motors, models IM B5 and B14	
<b>Coupling</b>	Three-piece claw coupling	



## Performance data

i	i ist		n <sub>1</sub> [rpm]					
			3000	1500	1000	750	500	150
5:1	29:6	n <sub>2</sub> [rpm]	600.0	300.0	200.0	150.0	100.0	30.0
		P <sub>1N</sub> [kW]	2.26	1.43	1.09	0.87	0.64	0.25
		T <sub>2N</sub> [Nm]	33	41	47	49	53	67
		P <sub>1NT</sub> [kW]	1.85	1.25	1.10	0.90	0.80	0.00
		Efficiency	0.94	0.94	0.93	0.87	0.90	0.86
7.5:1	29:4	n <sub>2</sub> [rpm]	400.0	200.0	133.0	100.0	66.0	20.0
		P <sub>1N</sub> [kW]	1.68	1.06	0.81	0.65	0.48	0.19
		T <sub>2N</sub> [Nm]	36	45	51	54	58	73
		P <sub>1NT</sub> [kW]	1.45	0.95	0.77	0.70	0.61	0.00
		Efficiency	0.92	0.91	0.90	0.89	0.87	0.82
10:1	39:4	n <sub>2</sub> [rpm]	300.0	150.0	100.0	75.0	50.0	15.0
		P <sub>1N</sub> [kW]	1.39	0.77	0.55	0.43	0.32	0.13
		T <sub>2N</sub> [Nm]	39	43	45	47	50	64
		P <sub>1NT</sub> [kW]	1.28	0.83	0.69	0.63	0.87	0.00
		Efficiency	0.91	0.90	0.88	0.87	0.85	0.81
13:1	52:4	n <sub>2</sub> [rpm]	230.0	115.0	76.0	57.0	38.0	11.0
		P <sub>1N</sub> [kW]	0.85	0.45	0.32	0.26	0.19	0.08
		T <sub>2N</sub> [Nm]	31	32	34	36	39	50
		P <sub>1NT</sub> [kW]	1.13	0.75	0.63	0.57	0.52	0.00
		Efficiency	0.88	0.87	0.85	0.84	0.83	0.80
15:1	29:2	n <sub>2</sub> [rpm]	200.0	100.0	66.0	50.0	33.0	10.0
		P <sub>1N</sub> [kW]	0.93	0.60	0.48	0.39	0.29	0.12
		T <sub>2N</sub> [Nm]	37	48	55	58	63	79
		P <sub>1NT</sub> [kW]	0.85	0.55	0.46	0.41	0.36	0.00
		Efficiency	0.86	0.84	0.82	0.81	0.78	0.72
20:1	39:2	n <sub>2</sub> [rpm]	150.0	75.0	50.0	37.0	25.0	7.5
		P <sub>1N</sub> [kW]	0.82	0.49	0.36	0.28	0.21	0.09
		T <sub>2N</sub> [Nm]	43	50	53	55	58	75
		P <sub>1NT</sub> [kW]	0.77	0.49	0.42	0.38	0.34	0.00
		Efficiency	0.84	0.82	0.80	0.78	0.76	0.71

i	i ist		n <sub>1</sub> [rpm]					
			3000	1500	1000	750	500	150
26:1	52:2	n <sub>2</sub> [rpm]	115.0	57.0	38.0	28.0	19.0	5.8
		P <sub>1N</sub> [kW]	0.55	0.30	0.21	0.17	0.12	0.05
		T <sub>2N</sub> [Nm]	36	38	40	42	45	59
		P <sub>1NT</sub> [kW]	0.68	0.44	0.38	0.34	0.31	0.00
		Efficiency	0.80	0.78	0.76	0.75	0.73	0.69
30:1	29:1	n <sub>2</sub> [rpm]	100.0	50.0	33.0	25.0	16.0	5.0
		P <sub>1N</sub> [kW]	0.53	0.37	0.29	0.24	0.18	0.08
		T <sub>2N</sub> [Nm]	36	50	57	60	65	82
		P <sub>1NT</sub> [kW]	0.51	0.33	0.28	0.26	0.23	0.00
		Efficiency	0.75	0.73	0.70	0.68	0.64	0.57
40:1	39:1	n <sub>2</sub> [rpm]	75.0	37.0	25.0	18.0	12.0	3.8
		P <sub>1N</sub> [kW]	0.48	0.32	0.25	0.20	0.15	0.07
		T <sub>2N</sub> [Nm]	44	56	63	66	71	91
		P <sub>1NT</sub> [kW]	0.46	0.30	0.25	0.23	0.21	0.00
		Efficiency	0.72	0.70	0.67	0.65	0.62	0.56
53:1	52:1	n <sub>2</sub> [rpm]	57.0	28.0	18.0	14.0	9.4	2.8
		P <sub>1N</sub> [kW]	0.39	0.21	0.15	0.13	0.09	0.04
		T <sub>2N</sub> [Nm]	44	46	48	51	55	72
		P <sub>1NT</sub> [kW]	0.42	0.28	0.24	0.22	0.20	0.00
		Efficiency	0.68	0.65	0.63	0.61	0.59	0.55
62:1	63:1	n <sub>2</sub> [rpm]	48.0	24.0	16.0	12.0	8.1	2.4
		P <sub>1N</sub> [kW]	0.36	0.20	0.15	0.12	0.09	0.03
		T <sub>2N</sub> [Nm]	45	48	51	53	56	57
		P <sub>1NT</sub> [kW]	0.35	0.23	0.20	0.18	0.16	0.00
		Efficiency	0.63	0.59	0.56	0.54	0.51	0.45
83:1	82:1	n <sub>2</sub> [rpm]	36.0	18.0	12.0	9.0	6.0	1.8
		P <sub>1N</sub> [kW]	0.25	0.14	0.10	0.08	0.05	0.02
		T <sub>2N</sub> [Nm]	36	37	38	38	38	38
		P <sub>1NT</sub> [kW]	0.32	0.21	0.18	0.17	0.15	0.00
		Efficiency	0.56	0.52	0.50	0.48	0.46	0.42

	5:1	7.5:1	10:1	13:1	15:1	20:1	26:1	30:1	40:1	53:1	62:1	83:1
T <sub>2max</sub> [Nm]	73	83	77	59	97	90	77	107	99	87	72	64

## Permissible radial force F<sub>r2</sub> and axial force F<sub>a2</sub> on shaft N<sub>2</sub>

n <sub>2</sub> [rpm]	200		125		75		50		30		10	
	F <sub>r</sub> [N]	F <sub>a</sub> [N]	F <sub>r</sub> [N]	F <sub>a</sub> [N]	F <sub>r</sub> [N]	F <sub>a</sub> [N]	F <sub>r</sub> [N]	F <sub>a</sub> [N]	F <sub>r</sub> [N]	F <sub>a</sub> [N]	F <sub>r</sub> [N]	F <sub>a</sub> [N]
< 80	970	485	1250	625	1380	690	1600	800	1800	900	2500	1250

## Inertia moments/mass

Inertia moment J<sub>1</sub> related to the fast-rotating shaft (N<sub>1</sub>)

J <sub>1</sub>	Inertia moment [kgcm <sup>2</sup> ]											
	5:1	7.5:1	10:1	13:1	15:1	20:1	26:1	30:1	40:1	53:1	62:1	83:1
J <sub>1</sub>	0.68	0.60	0.53	0.50	0.54	0.50	0.48	0.53	0.49	0.47	0.48	0.47

Mass  
ca. [kg]  
7

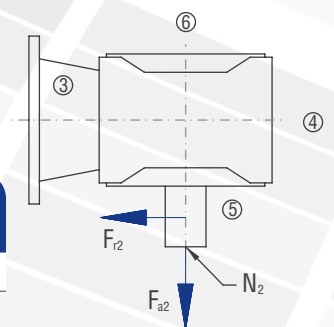

The mass of the gearbox may deviate depending on the flange size, the type and the gear ratio.

# 9.4.6 Type SL 040 – Type S with flange for motor mounting

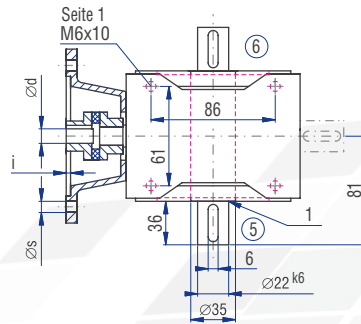
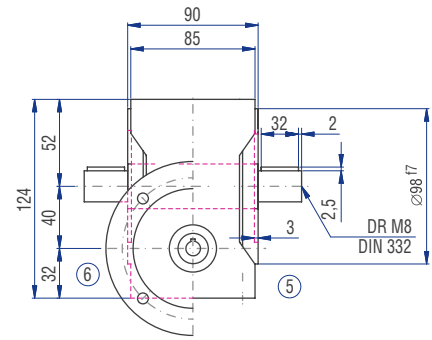
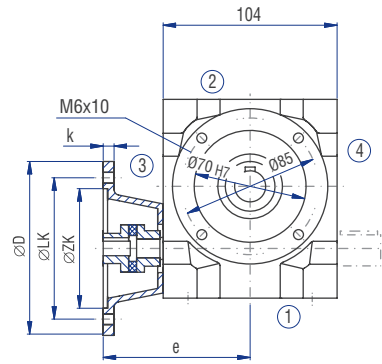
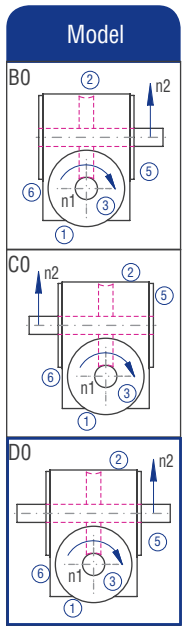

## Implementation VV

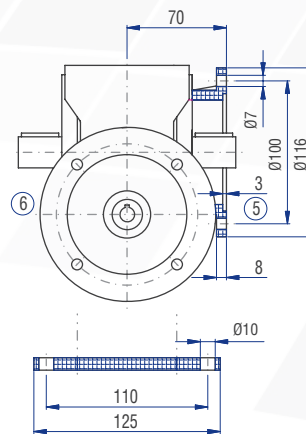
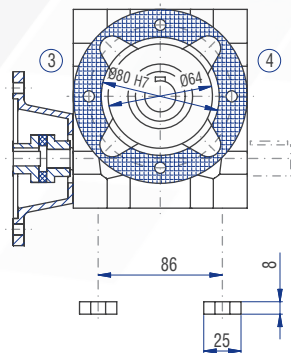
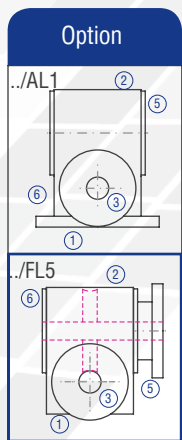
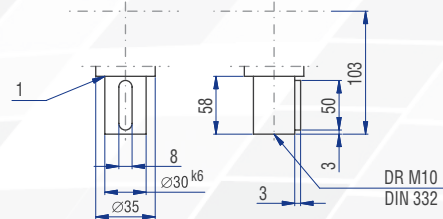

IEC motor	Model	Motor shaft (dxl)	Flange diameter D [mm]	LK [mm]	ZK [mm]	s [mm]	i [mm]	k [mm]	e [mm]
63	B14	11x23	120	100	80	7	3	10	121
	B5	11x23	140	115	95	9	3	10	121
71	B14	14x30	140	115	95	9	3	10	121
	B14	14x30	105	85	70	7	3	10	121

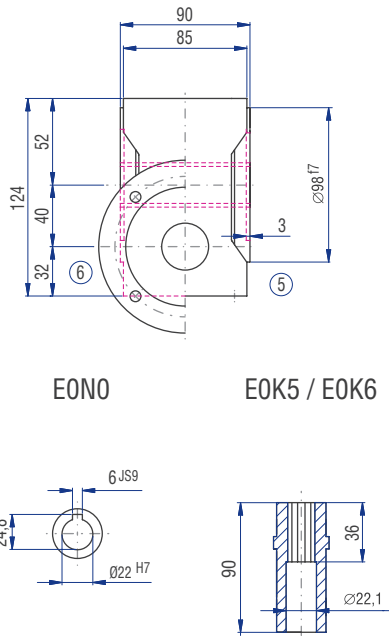
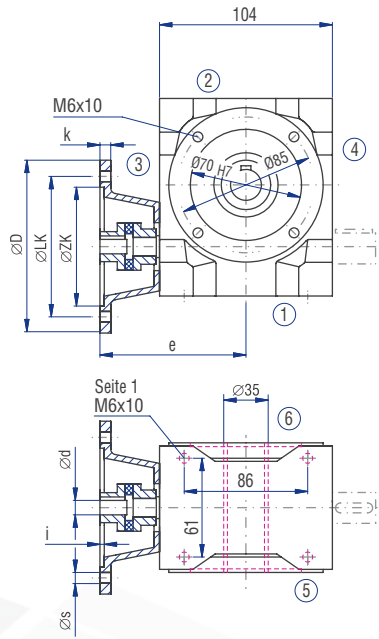

EON0

EOK5 / EOK6

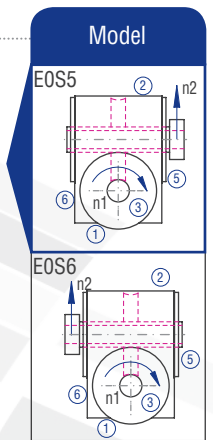
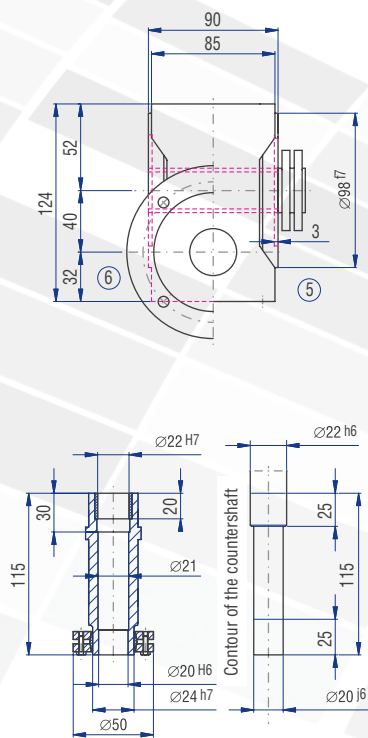
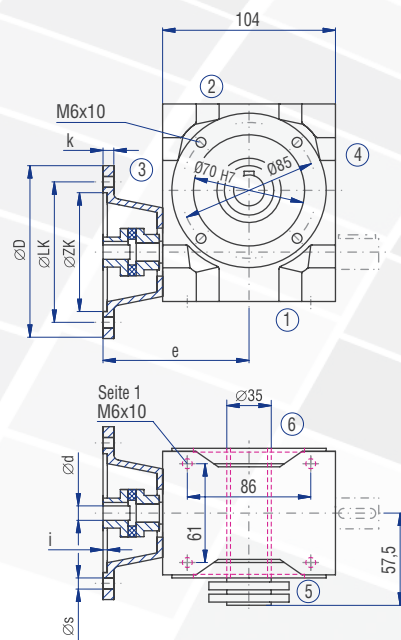
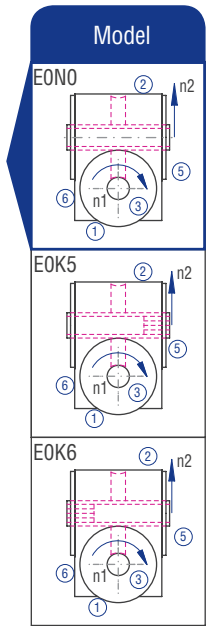
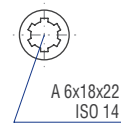

Worm  
gearboxes

## 9.4.7 Type SL 050 – Type S with flange for motor mounting

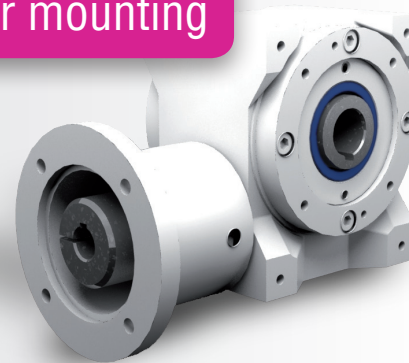

### Characteristics

Characteristic	Standard	Option
<b>Toothing</b>	Hardened and ground worm shaft / bronze worm gear	See chapter 9.2.1
<b>Gear ratio</b>	5:1 to 83:1	
<b>Housing / Flanges</b>	Grey cast iron	
<b>Threaded mounting hole</b>	On gearbox side 1 and on the flanges	See chapter 9.2.3
<b>Shaft</b>	Material 1 C45, shaft ends greased Fit with ISO j6 tolerance with parallel keyway: according to DIN 6885 Sheet 1	See chapter 4.6.2
<b>Hollow shaft</b>	Material 1 C45, shafts greased Fit with ISO H7 tolerance with parallel keyway: according to DIN 6885 Sheet 1	See chapter 4.6.3
<b>Radial shaft seal ring</b>	NBR, form A	See chapter 4.8
<b>Ambient temperature</b>	-10°C to +90°C. The values of the performance tables are valid for 20°C	See chapter 4.9.3
<b>Circumferential backlash</b>	< 30 arcmin	See chapter 9.2.10
<b>Protection class</b>	IP 54	See chapter 4.5
<b>Corrosion protection</b>	Prime coat; layer thickness > 40 µm	See chapter 4.4.1
<b>Bearing life L10h</b>	more than 15,000h	See chapter 4.9.1
<b>Oil change intervals</b>	Not required if the oil temperature is kept below 90°C. The lifetime of the bearings can be increased by the factor 1.5 if the oil is changed after the first 500 service hours and then every 5000 service hours.	See chapter 9.2.8
<b>Lubricants</b>	Synthetic lubricants	See chapter 9.2.8
<b>Flange</b>	Suited for the mounting of IEC motors, models IM B5 and B14	
<b>Coupling</b>	Three-piece claw coupling	

## Performance data

i	i ist		n <sub>1</sub> [rpm]					
			3000	1500	1000	750	500	150
5:1	29:6	n <sub>2</sub> [rpm]	600.0	300.0	200.0	150.0	100.0	30.0
		P <sub>1N</sub> [kW]	4.74	3.29	2.54	2.08	1.47	0.54
		T <sub>2N</sub> [Nm]	70	96	110	119	125	145
		P <sub>1NT</sub> [kW]	3.90	2.76	2.10	2.04	1.76	0.00
		Efficiency	0.96	0.95	0.94	0.93	0.92	0.88
7.5:1	29:4	n <sub>2</sub> [rpm]	400.0	200.0	133.0	100.0	66.0	20.0
		P <sub>1N</sub> [kW]	3.41	2.42	1.84	1.43	1.01	0.40
		T <sub>2N</sub> [Nm]	74	104	117	120	125	153
		P <sub>1NT</sub> [kW]	3.16	2.12	1.76	1.57	1.36	0.00
		Efficiency	0.94	0.93	0.92	0.91	0.89	0.83
10:1	38:4	n <sub>2</sub> [rpm]	300.0	150.0	100.0	75.0	50.0	15.0
		P <sub>1N</sub> [kW]	3.02	1.64	1.15	0.96	0.71	0.26
		T <sub>2N</sub> [Nm]	85	91	94	103	112	130
		P <sub>1NT</sub> [kW]	2.82	1.88	1.56	1.40	1.23	0.00
		Efficiency	0.93	0.92	0.90	0.89	0.87	0.82
13:1	51:4	n <sub>2</sub> [rpm]	230.0	115.0	76.0	57.0	38.0	11.0
		P <sub>1N</sub> [kW]	1.51	0.82	0.58	0.45	0.32	0.12
		T <sub>2N</sub> [Nm]	55	59	62	64	66	75
		P <sub>1NT</sub> [kW]	2.51	1.67	1.14	1.27	1.13	0.00
		Efficiency	0.90	0.89	0.88	0.87	0.85	0.80
15:1	29:2	n <sub>2</sub> [rpm]	200.0	100.0	66.0	50.0	33.0	10.0
		P <sub>1N</sub> [kW]	1.82	1.32	1.02	0.84	0.65	0.26
		T <sub>2N</sub> [Nm]	74	106	120	131	145	179
		P <sub>1NT</sub> [kW]	1.91	1.27	1.05	0.94	0.82	0.00
		Efficiency	0.88	0.87	0.85	0.84	0.81	0.74
20:1	38:2	n <sub>2</sub> [rpm]	150.0	75.0	50.0	37.0	25.0	7.5
		P <sub>1N</sub> [kW]	1.54	1.03	0.73	0.63	0.47	0.18
		T <sub>2N</sub> [Nm]	81	106	110	123	133	158
		P <sub>1NT</sub> [kW]	1.70	1.12	0.93	0.84	0.74	0.00
		Efficiency	0.87	0.85	0.83	0.81	0.78	0.72
26:1	51:2	n <sub>2</sub> [rpm]	115.0	57.0	38.0	28.0	19.0	5.8
		P <sub>1N</sub> [kW]	1.04	0.58	0.42	0.32	0.24	0.09
		T <sub>2N</sub> [Nm]	71	76	80	82	86	98
		P <sub>1NT</sub> [kW]	1.51	1.00	0.84	0.76	0.68	0.00
		Efficiency	0.84	0.81	0.79	0.78	0.75	0.70
30:1	29:1	n <sub>2</sub> [rpm]	100.0	50.0	33.0	25.0	16.0	5.0
		P <sub>1N</sub> [kW]	1.12	0.79	0.59	0.54	0.42	0.18
		T <sub>2N</sub> [Nm]	82	113	121	144	157	201
		P <sub>1NT</sub> [kW]	1.14	0.76	0.63	0.60	0.50	0.00
		Efficiency	0.79	0.77	0.74	0.72	0.68	0.59
40:1	38:1	n <sub>2</sub> [rpm]	75.0	37.0	25.0	18.0	12.0	3.8
		P <sub>1N</sub> [kW]	0.87	0.65	0.52	0.41	0.31	0.13
		T <sub>2N</sub> [Nm]	80	118	134	137	147	183
		P <sub>1NT</sub> [kW]	1.02	0.68	0.57	0.52	0.46	0.00
		Efficiency	0.76	0.75	0.71	0.69	0.65	0.57
53:1	51:1	n <sub>2</sub> [rpm]	57.0	28.0	18.0	14.0	9.4	2.8
		P <sub>1N</sub> [kW]	0.65	0.38	0.27	0.22	0.16	0.06
		T <sub>2N</sub> [Nm]	77	85	88	91	95	110
		P <sub>1NT</sub> [kW]	0.92	0.62	0.52	0.48	0.43	0.00
		Efficiency	0.73	0.69	0.67	0.64	0.61	0.55
62:1	62:1	n <sub>2</sub> [rpm]	48.0	24.0	16.0	12.0	8.1	2.4
		P <sub>1N</sub> [kW]	0.61	0.42	0.31	0.25	0.18	0.06
		T <sub>2N</sub> [Nm]	81	105	109	112	113	113
		P <sub>1NT</sub> [kW]	0.75	0.50	0.43	0.39	0.36	0.00
		Efficiency	0.67	0.64	0.60	0.57	0.53	0.45
83:1	83:1	n <sub>2</sub> [rpm]	36.0	18.0	12.0	9.0	6.0	1.8
		P <sub>1N</sub> [kW]	0.39	0.21	0.15	0.12	0.09	0.03
		T <sub>2N</sub> [Nm]	59	63	64	66	69	75
		P <sub>1NT</sub> [kW]	0.70	0.47	0.41	0.37	0.34	0.00
		Efficiency	0.58	0.56	0.54	0.52	0.49	0.44

	5:1	7.5:1	10:1	13:1	15:1	20:1	26:1	30:1	40:1	53:1	62:1	83:1
T <sub>2max</sub> [Nm]	150	167	152	100	195	179	137	219	197	145	120	112

## Permissible radial force F<sub>r2</sub> and axial force F<sub>a2</sub> on shaft N<sub>2</sub>

n <sub>2</sub> [rpm]	200		125		75		50		30		10	
	F <sub>r</sub> [N]	F <sub>a</sub> [N]	F <sub>r</sub> [N]	F <sub>a</sub> [N]	F <sub>r</sub> [N]	F <sub>a</sub> [N]	F <sub>r</sub> [N]	F <sub>a</sub> [N]	F <sub>r</sub> [N]	F <sub>a</sub> [N]	F <sub>r</sub> [N]	F <sub>a</sub> [N]
< 120	2000	1000	2400	1200	2850	1425	3350	1675	4000	2000	4800	2400
> 120	1540	770	1850	925	2190	1095	2580	1290	3080	1540	3700	1850

## Inertia moments/mass

Inertia moment J<sub>1</sub> related to the fast-rotating shaft (N<sub>1</sub>)

J <sub>1</sub>	Inertia moment [kgcm <sup>2</sup> ]											
	5:1	7.5:1	10:1	13:1	15:1	20:1	26:1	30:1	40:1	53:1	62:1	83:1
J <sub>1</sub>	2.03	1.81	1.66	1.57	1.68	1.58	1.52	1.65	1.56	1.50	1.55	1.50

Mass  
ca. [kg]  
14

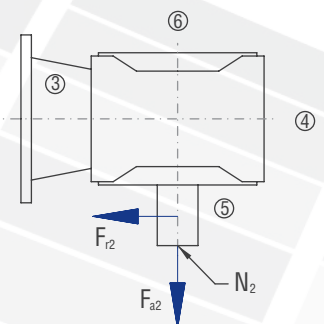

The mass of the gearbox may deviate depending on the flange size, the type and the gear ratio.

# 9.4.7 Type SL 050 – Type S with flange for motor mounting

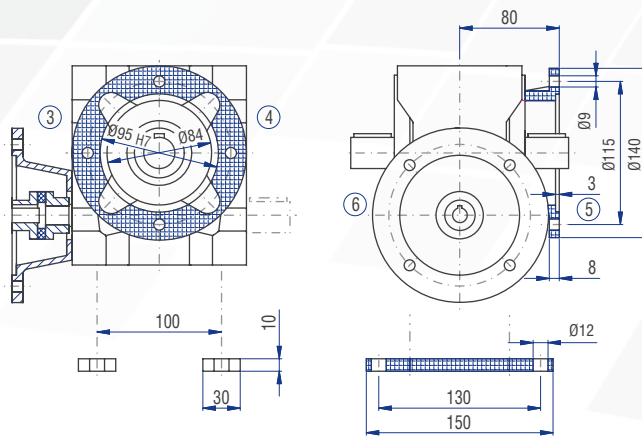
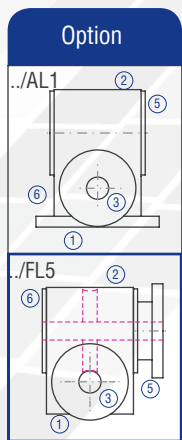
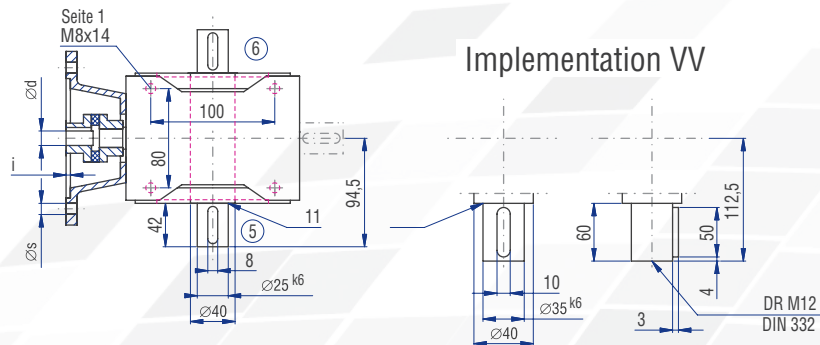
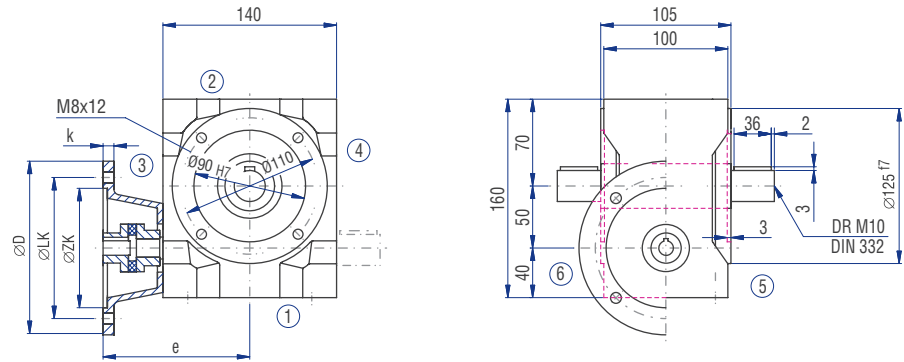
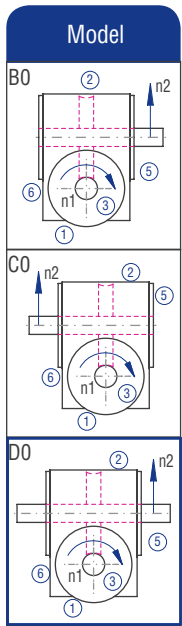

IEC motor	Model	Motor shaft (dxl)	Flange diameter D [mm]	LK [mm]	ZK [mm]	s [mm]	i [mm]	k [mm]	e [mm]
63	B14	11x23	120	100	80	7	3	9	150
	B14	19x40	120	100	80	7	3	9	150
80	B14	19x40	160	130	110	9	4	10	150
	B14	24x50	160a	130	110	9	4	20	160



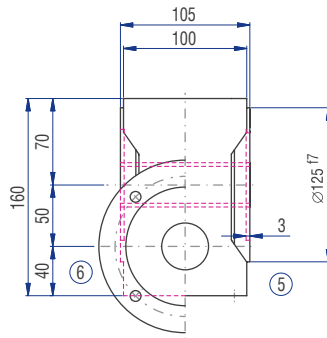
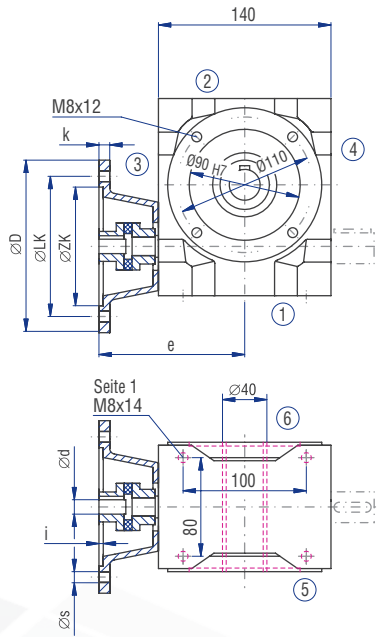

EON0

EOK5 / EOK6

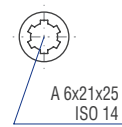
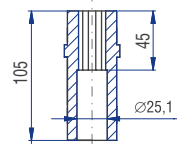
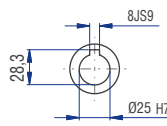

Model

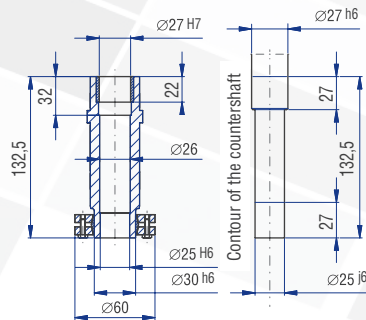
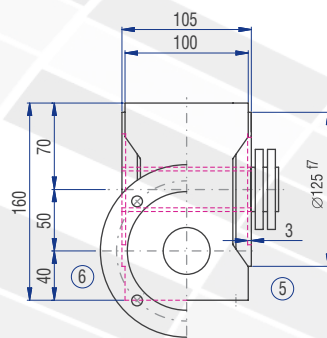
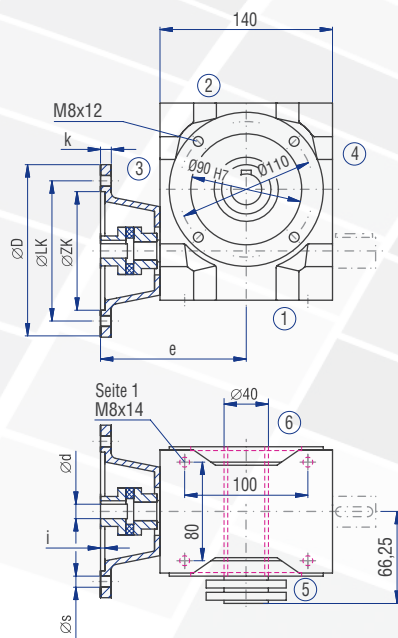
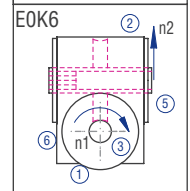
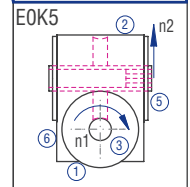
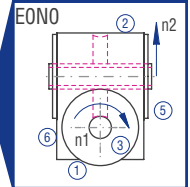

Model

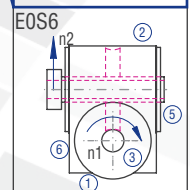
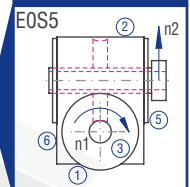

Worm  
gearboxes

## 9.4.8 Type SL 063 – Type S with flange for motor mounting

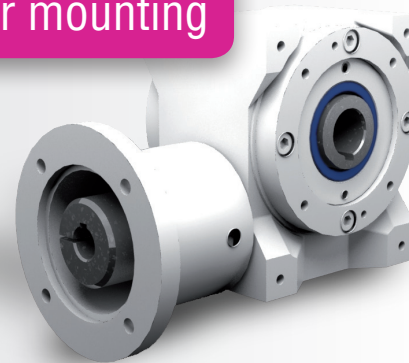

### Characteristics

Characteristic	Standard	Option
<b>Toothing</b>	Hardened and ground worm shaft / bronze worm gear	See chapter 9.2.1
<b>Gear ratio</b>	5:1 to 83:1	
<b>Housing / Flanges</b>	Grey cast iron	
<b>Threaded mounting hole</b>	On gearbox side 1 and on the flanges	See chapter 9.2.3
<b>Shaft</b>	Material 1 C45, shaft ends greased Fit with ISO j6 tolerance with parallel keyway: according to DIN 6885 Sheet 1	See chapter 4.6.2
<b>Hollow shaft</b>	Material 1 C45, shafts greased Fit with ISO H7 tolerance with parallel keyway: according to DIN 6885 Sheet 1	See chapter 4.6.3
<b>Radial shaft seal ring</b>	NBR, form A	See chapter 4.8
<b>Ambient temperature</b>	-10°C to +90°C. The values of the performance tables are valid for 20°C	See chapter 4.9.3
<b>Circumferential backlash</b>	< 30 arcmin	See chapter 9.2.10
<b>Protection class</b>	IP 54	See chapter 4.5
<b>Corrosion protection</b>	Prime coat; layer thickness > 40 µm	See chapter 4.4.1
<b>Bearing life L10h</b>	more than 15,000h	See chapter 4.9.1
<b>Oil change intervals</b>	Not required if the oil temperature is kept below 90°C. The lifetime of the bearings can be increased by the factor 1.5 if the oil is changed after the first 500 service hours and then every 5000 service hours.	See chapter 9.2.8
<b>Lubricants</b>	Synthetic lubricants	See chapter 9.2.8
<b>Flange</b>	Suited for the mounting of IEC motors, models IM B5 and B14	
<b>Coupling</b>	Three-piece claw coupling	

## Performance data

i	i ist		n <sub>1</sub> [rpm]					
			3000	1500	1000	750	500	150
5:1	29:6	n <sub>2</sub> [rpm]	600.0	300.0	200.0	150.0	100.0	30.0
		P <sub>1N</sub> [kW]	6.37	4.96	3.77	3.11	2.31	0.91
		T <sub>2N</sub> [Nm]	94	145	165	180	198	247
		P <sub>1NT</sub> [kW]	5.80	4.25	3.56	3.15	2.67	0.00
		Efficiency	0.96	0.95	0.95	0.94	0.93	0.88
7.5:1	29:4	n <sub>2</sub> [rpm]	400.0	200.0	133.0	100.0	66.0	20.0
		P <sub>1N</sub> [kW]	4.89	3.62	2.78	2.37	1.79	0.72
		T <sub>2N</sub> [Nm]	106	157	179	201	223	280
		P <sub>1NT</sub> [kW]	4.63	3.26	2.72	2.41	2.06	0.00
		Efficiency	0.94	0.94	0.93	0.92	0.90	0.84
10:1	39:4	n <sub>2</sub> [rpm]	300.0	150.0	100.0	75.0	50.0	15.0
		P <sub>1N</sub> [kW]	4.15	2.94	2.26	1.83	1.30	0.51
		T <sub>2N</sub> [Nm]	121	170	194	207	216	265
		P <sub>1NT</sub> [kW]	4.16	2.89	2.41	2.15	1.86	0.00
		Efficiency	0.94	0.93	0.92	0.91	0.89	0.83
13:1	51:4	n <sub>2</sub> [rpm]	230.0	115.0	76.0	57.0	38.0	11.0
		P <sub>1N</sub> [kW]	3.31	1.81	1.29	1.00	0.71	0.26
		T <sub>2N</sub> [Nm]	125	135	141	145	151	170
		P <sub>1NT</sub> [kW]	3.68	2.53	2.12	1.90	1.66	0.00
		Efficiency	0.93	0.92	0.90	0.89	0.87	0.82
15:1	29:2	n <sub>2</sub> [rpm]	200.0	100.0	66.0	50.0	33.0	10.0
		P <sub>1N</sub> [kW]	3.12	2.23	1.77	1.51	1.16	0.48
		T <sub>2N</sub> [Nm]	128	183	213	240	266	333
		P <sub>1NT</sub> [kW]	2.80	1.95	1.62	1.44	1.23	0.00
		Efficiency	0.89	0.00	0.00	0.86	0.83	0.75
20:1	39:2	n <sub>2</sub> [rpm]	150.0	75.0	50.0	37.0	25.0	7.5
		P <sub>1N</sub> [kW]	2.95	1.70	1.32	1.14	0.86	0.34
		T <sub>2N</sub> [Nm]	161	186	212	237	259	310
		P <sub>1NT</sub> [kW]	2.52	1.73	1.44	1.29	1.12	0.00
		Efficiency	0.88	0.88	0.86	0.84	0.81	0.74

i	i ist		n <sub>1</sub> [rpm]					
			3000	1500	1000	750	500	150
26:1	51:2	n <sub>2</sub> [rpm]	115.0	57.0	38.0	28.0	19.0	5.8
		P <sub>1N</sub> [kW]	1.89	1.25	0.90	0.71	0.51	0.19
		T <sub>2N</sub> [Nm]	132	173	181	187	195	222
		P <sub>1NT</sub> [kW]	2.21	1.52	1.27	1.14	1.01	0.00
		Efficiency	0.86	0.85	0.83	0.81	0.78	0.71
30:1	29:1	n <sub>2</sub> [rpm]	100.0	50.0	33.0	25.0	16.0	5.0
		P <sub>1N</sub> [kW]	1.94	1.38	1.11	0.97	0.75	0.36
		T <sub>2N</sub> [Nm]	143	204	237	268	296	403
		P <sub>1NT</sub> [kW]	1.66	1.15	0.97	0.86	0.75	0.00
		Efficiency	0.80	0.80	0.77	0.75	0.71	0.61
40:1	39:1	n <sub>2</sub> [rpm]	75.0	37.0	25.0	18.0	12.0	3.8
		P <sub>1N</sub> [kW]	1.54	1.08	0.85	0.74	0.57	0.24
		T <sub>2N</sub> [Nm]	149	207	237	264	288	348
		P <sub>1NT</sub> [kW]	1.50	1.04	0.87	0.78	0.69	0.00
		Efficiency	0.78	0.77	0.75	0.72	0.68	0.59
53:1	51:1	n <sub>2</sub> [rpm]	57.0	28.0	18.0	14.0	9.4	2.8
		P <sub>1N</sub> [kW]	1.16	0.80	0.58	0.47	0.34	0.14
		T <sub>2N</sub> [Nm]	143	191	200	207	217	248
		P <sub>1NT</sub> [kW]	1.34	0.96	0.78	0.71	0.63	0.00
		Efficiency	0.76	0.74	0.71	0.68	0.65	0.56
62:1	61:1	n <sub>2</sub> [rpm]	48.0	24.0	16.0	12.0	8.1	2.4
		P <sub>1N</sub> [kW]	0.82	0.66	0.53	0.46	0.34	0.12
		T <sub>2N</sub> [Nm]	110	175	202	221	226	226
		P <sub>1NT</sub> [kW]	1.10	0.76	0.65	0.59	0.52	0.00
		Efficiency	0.69	0.68	0.65	0.62	0.57	0.47
83:1	82:1	n <sub>2</sub> [rpm]	36.0	18.0	12.0	9.0	6.0	1.8
		P <sub>1N</sub> [kW]	0.75	0.46	0.33	0.26	0.19	0.07
		T <sub>2N</sub> [Nm]	129	152	152	152	152	152
		P <sub>1NT</sub> [kW]	0.99	0.69	0.59	0.54	0.49	0.00
		Efficiency	0.66	0.63	0.59	0.56	0.52	0.44

	5:1	7.5:1	10:1	13:1	15:1	20:1	26:1	30:1	40:1	53:1	62:1	83:1
T <sub>2max</sub> [Nm]	295	334	306	222	395	355	295	437	360	310	240	246

## Permissible radial force F<sub>r2</sub> and axial force F<sub>a2</sub> on shaft N<sub>2</sub>

n <sub>2</sub> [rpm]	200		125		75		50		30		10	
	F <sub>r</sub> [N]	F <sub>a</sub> [N]	F <sub>r</sub> [N]	F <sub>a</sub> [N]	F <sub>r</sub> [N]	F <sub>a</sub> [N]	F <sub>r</sub> [N]	F <sub>a</sub> [N]	F <sub>r</sub> [N]	F <sub>a</sub> [N]	F <sub>r</sub> [N]	F <sub>a</sub> [N]
< 220	2700	1350	3150	1575	3800	1900	4500	2250	5200	2600	5200	2600
> 220	2080	1040	2420	1210	2920	1460	3460	1730	4000	2000	4000	2000

## Inertia moments/mass

Inertia moment J<sub>1</sub> related to the fast-rotating shaft (N<sub>1</sub>)

J <sub>1</sub>	Inertia moment [kgcm <sup>2</sup> ]											
	5:1	7.5:1	10:1	13:1	15:1	20:1	26:1	30:1	40:1	53:1	62:1	83:1
J <sub>1</sub>	3.25	2.72	2.22	2.02	2.41	2.02	1.90	2.33	1.98	1.87	2.05	1.88

Mass  
ca. [kg]  
21

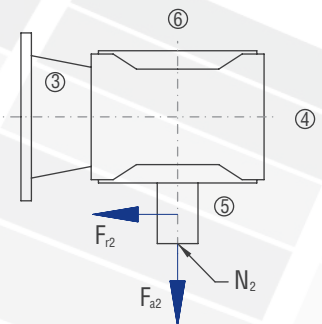

The mass of the gearbox may deviate depending on the flange size, the type and the gear ratio.

## 9.4.8 Type SL 063 – Type S with flange for motor mounting

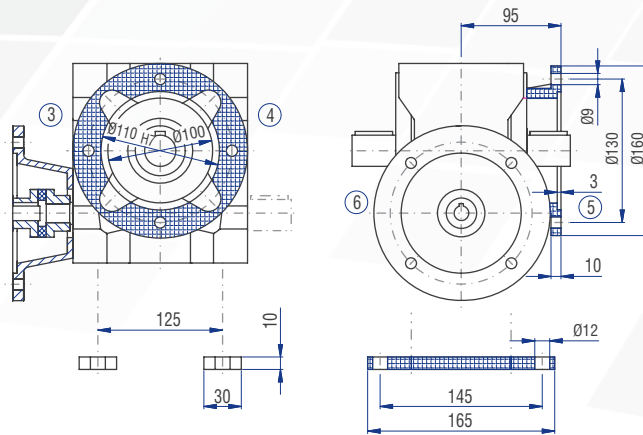
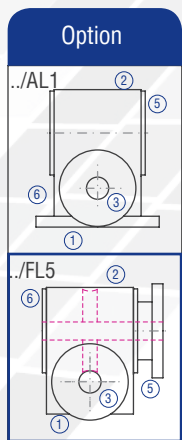
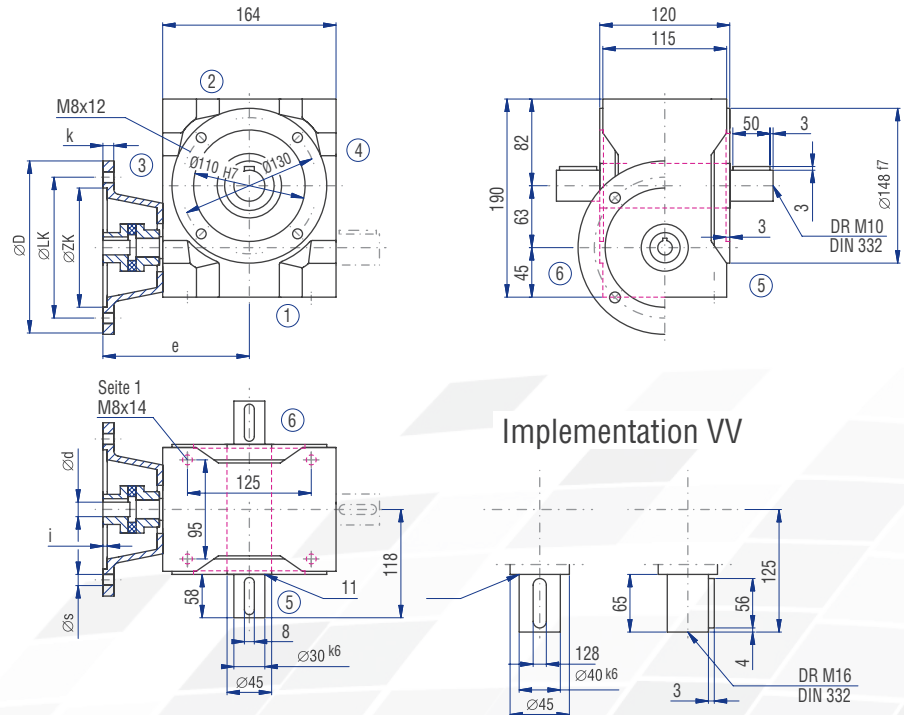
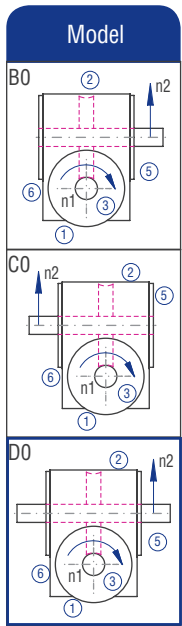

IEC motor	Model	Motor shaft (dxl)	Flange diameter D [mm]	LK [mm]	ZK [mm]	s [mm]	i [mm]	k [mm]	e [mm]
71	B5	14x30	160	130	110	9	4	10	163
80	B14	19x40	160	130	110	9	4	10	163
	B5	19x40	200	165	130	11	4	10	175
90	B14	24x50	160a	130	110	9	4	10	175
	B5	24x50	200	165	130	11	4	10	175
100	B14	28x60	200a	165	130	11	4	20	185
112	B14	28x60	200a	165	130	11	4	20	185

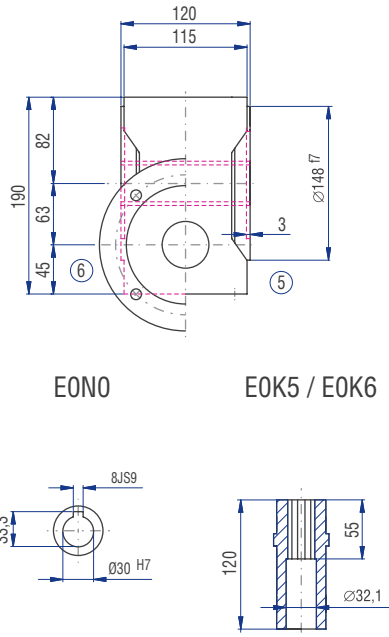
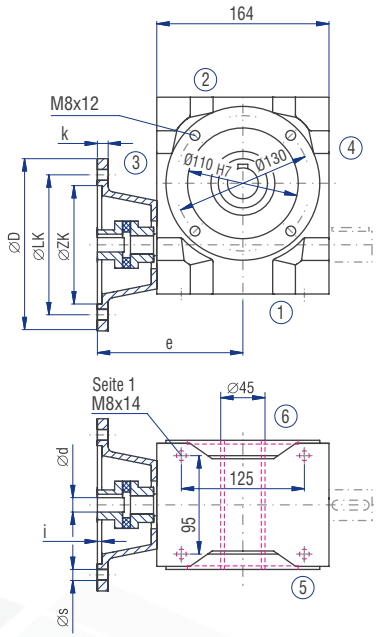

EON0

EOK5 / EOK6

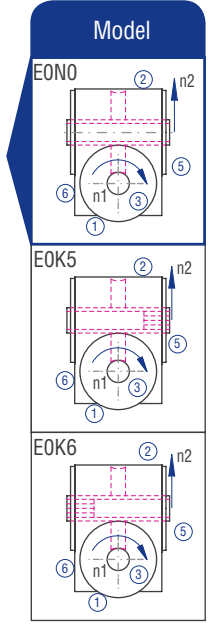
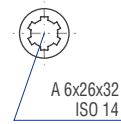

Worm  
gearboxes

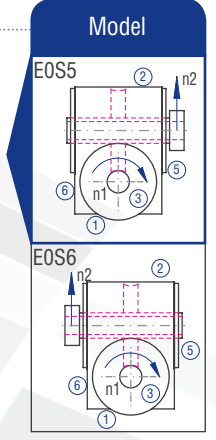
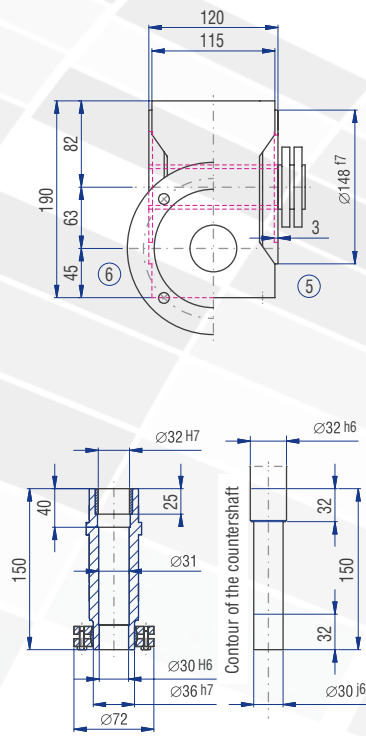
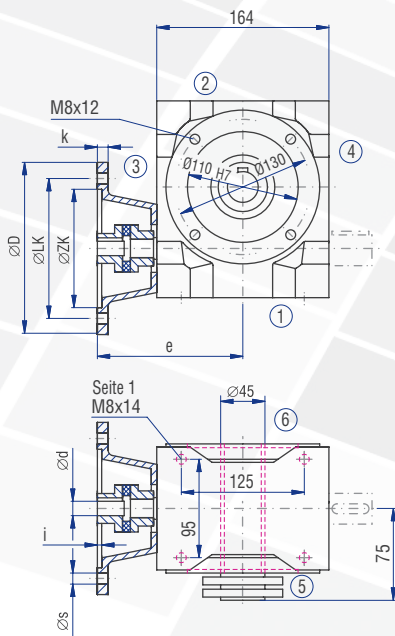

## 9.4.9 Type SL 080 – Type S with flange for motor mounting

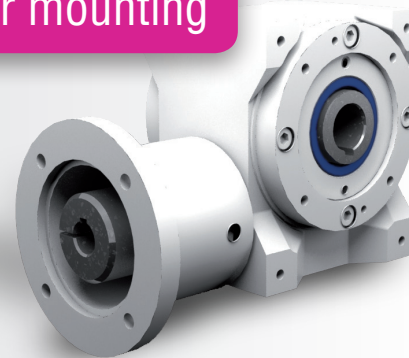

### Characteristics

Characteristic	Standard	Option
<b>Toothing</b>	Hardened and ground worm shaft / bronze worm gear	See chapter 9.2.1
<b>Gear ratio</b>	5:1 to 83:1	
<b>Housing / Flanges</b>	Grey cast iron	
<b>Threaded mounting hole</b>	On gearbox side 1 and on the flanges	See chapter 9.2.3
<b>Shaft</b>	Material 1 C45, shaft ends greased Fit with ISO j6 tolerance with parallel keyway: according to DIN 6885 Sheet 1	See chapter 4.6.2
<b>Hollow shaft</b>	Material 1 C45, shafts greased Fit with ISO H7 tolerance with parallel keyway: according to DIN 6885 Sheet 1	See chapter 4.6.3
<b>Radial shaft seal ring</b>	NBR, form A	See chapter 4.8
<b>Ambient temperature</b>	-10°C to +90°C. The values of the performance tables are valid for 20°C	See chapter 4.9.3
<b>Circumferential backlash</b>	< 30 arcmin	See chapter 9.2.10
<b>Protection class</b>	IP 54	See chapter 4.5
<b>Corrosion protection</b>	Prime coat; layer thickness > 40 µm	See chapter 4.4.1
<b>Bearing life L10h</b>	more than 15,000h	See chapter 4.9.1
<b>Oil change intervals</b>	Not required if the oil temperature is kept below 90°C. The lifetime of the bearings can be increased by the factor 1.5 if the oil is changed after the first 500 service hours and then every 5000 service hours.	See chapter 9.2.8
<b>Lubricants</b>	Synthetic lubricants	See chapter 9.2.8
<b>Flange</b>	Suited for the mounting of IEC motors, models IM B5 and B14	
<b>Coupling</b>	Three-piece claw coupling	



## Performance data

i	i ist		n <sub>1</sub> [rpm]					
			3000	1500	1000	750	500	150
5:1	30:6	n <sub>2</sub> [rpm]	600.0	300.0	200.0	150.0	100.0	30.0
		P <sub>1N</sub> [kW]	11.13	8.18	4.36	5.55	4.01	1.58
		T <sub>2N</sub> [Nm]	170	250	298	332	360	448
		P <sub>1NT</sub> [kW]	8.62	6.68	5.70	5.05	4.24	0.00
		Efficiency	0.96	0.96	0.95	0.94	0.94	0.89
7.5:1	30:4	n <sub>2</sub> [rpm]	400.0	200.0	133.0	100.0	66.0	20.0
		P <sub>1N</sub> [kW]	8.64	6.37	5.01	4.36	3.33	1.39
		T <sub>2N</sub> [Nm]	196	289	341	391	439	569
		P <sub>1NT</sub> [kW]	6.69	5.14	4.37	3.88	3.27	0.00
		Efficiency	0.95	0.95	0.95	0.94	0.92	0.86
10:1	40:4	n <sub>2</sub> [rpm]	300.0	150.0	100.0	75.0	50.0	15.0
		P <sub>1N</sub> [kW]	6.58	4.96	3.79	3.15	2.35	0.96
		T <sub>2N</sub> [Nm]	197	297	340	373	408	513
		P <sub>1NT</sub> [kW]	5.92	4.47	3.79	3.36	2.86	0.00
		Efficiency	0.94	0.94	0.94	0.93	0.91	0.84
13:1	53:4	n <sub>2</sub> [rpm]	230.0	115.0	76.0	57.0	38.0	11.0
		P <sub>1N</sub> [kW]	4.41	2.41	1.70	1.33	0.94	0.34
		T <sub>2N</sub> [Nm]	173	187	196	202	210	236
		P <sub>1NT</sub> [kW]	5.27	3.91	3.32	2.96	2.56	0.00
		Efficiency	0.93	0.92	0.91	0.90	0.88	0.83
15:1	30:2	n <sub>2</sub> [rpm]	200.0	100.0	66.0	50.0	33.0	10.0
		P <sub>1N</sub> [kW]	5.61	4.10	3.26	2.81	2.18	0.93
		T <sub>2N</sub> [Nm]	241	352	415	473	530	681
		P <sub>1NT</sub> [kW]	4.08	3.09	2.62	2.32	1.97	0.00
		Efficiency	0.90	0.90	0.89	0.88	0.85	0.77
20:1	40:2	n <sub>2</sub> [rpm]	150.0	75.0	50.0	37.0	25.0	7.5
		P <sub>1N</sub> [kW]	4.24	3.04	2.37	2.05	1.57	0.64
		T <sub>2N</sub> [Nm]	240	344	399	450	498	615
		P <sub>1NT</sub> [kW]	3.59	2.67	2.26	2.01	1.72	0.00
		Efficiency	0.89	0.89	0.88	0.86	0.83	0.75
26:1	53:2	n <sub>2</sub> [rpm]	115.0	57.0	38.0	28.0	19.0	5.8
		P <sub>1N</sub> [kW]	2.83	1.67	1.19	0.94	0.68	0.25
		T <sub>2N</sub> [Nm]	210	245	256	264	275	312
		P <sub>1NT</sub> [kW]	3.19	2.34	1.99	1.78	1.55	0.00
		Efficiency	0.88	0.87	0.85	0.83	0.80	0.73
30:1	30:1	n <sub>2</sub> [rpm]	100.0	50.0	33.0	25.0	16.0	5.0
		P <sub>1N</sub> [kW]	3.47	2.52	2.03	1.78	1.38	0.63
		T <sub>2N</sub> [Nm]	272	395	456	530	593	760
		P <sub>1NT</sub> [kW]	2.41	1.81	1.54	1.38	1.18	0.00
		Efficiency	0.82	0.82	0.80	0.78	0.75	0.63
40:1	40:1	n <sub>2</sub> [rpm]	75.0	37.0	25.0	18.0	12.0	3.8
		P <sub>1N</sub> [kW]	2.62	1.87	1.49	1.31	1.02	0.40
		T <sub>2N</sub> [Nm]	267	381	443	501	553	625
		P <sub>1NT</sub> [kW]	2.14	1.58	1.35	1.21	1.05	0.00
		Efficiency	0.80	0.80	0.78	0.75	0.71	0.61
53:1	53:1	n <sub>2</sub> [rpm]	57.0	28.0	18.0	14.0	9.4	2.8
		P <sub>1N</sub> [kW]	1.78	1.04	0.76	0.61	0.45	0.18
		T <sub>2N</sub> [Nm]	234	271	284	294	308	352
		P <sub>1NT</sub> [kW]	1.93	1.41	1.20	1.09	0.96	0.00
		Efficiency	0.78	0.77	0.74	0.71	0.68	0.58
62:1	62:1	n <sub>2</sub> [rpm]	48.0	24.0	16.0	12.0	8.1	2.4
		P <sub>1N</sub> [kW]	1.40	1.01	0.81	0.69	0.54	0.23
		T <sub>2N</sub> [Nm]	194	279	325	352	393	448
		P <sub>1NT</sub> [kW]	1.55	1.15	0.98	0.89	0.78	0.00
		Efficiency	0.70	0.70	0.68	0.65	0.61	0.49
83:1	82:1	n <sub>2</sub> [rpm]	36.0	18.0	12.0	9.0	6.0	1.8
		P <sub>1N</sub> [kW]	1.10	0.90	0.64	0.49	0.35	0.13
		T <sub>2N</sub> [Nm]	196	304	304	304	304	304
		P <sub>1NT</sub> [kW]	1.43	1.04	0.90	0.82	0.73	0.00
		Efficiency	0.68	0.65	0.61	0.59	0.55	0.46

	5:1	7.5:1	10:1	13:1	15:1	20:1	26:1	30:1	40:1	53:1	62:1	83:1
T <sub>2max</sub> [Nm]	610	695	625	321	826	725	432	920	780	480	480	510

## Permissible radial force F<sub>r2</sub> and axial force F<sub>a2</sub> on shaft N<sub>2</sub>

n <sub>2</sub> [rpm]	200		125		75		50		30		10	
	F <sub>r</sub> [N]	F <sub>a</sub> [N]	F <sub>r</sub> [N]	F <sub>a</sub> [N]	F <sub>r</sub> [N]	F <sub>a</sub> [N]	F <sub>r</sub> [N]	F <sub>a</sub> [N]	F <sub>r</sub> [N]	F <sub>a</sub> [N]	F <sub>r</sub> [N]	F <sub>a</sub> [N]
< 430	3300	1650	3750	1875	4500	2250	5300	2650	6300	3150	7600	3800
> 430	2640	1320	3000	1500	3600	1800	4240	2120	5040	2520	6080	3040

## Inertia moments/mass

Inertia moment J<sub>1</sub> related to the fast-rotating shaft (N<sub>1</sub>)

J <sub>1</sub>	Inertia moment [kgcm <sup>2</sup> ]											
	5:1	7.5:1	10:1	13:1	15:1	20:1	26:1	30:1	40:1	53:1	62:1	83:1
J <sub>1</sub>	6.90	5.30	4.04	3.34	4.34	3.48	2.99	4.09	3.34	2.90	3.59	2.99

Mass  
ca. [kg]  
33

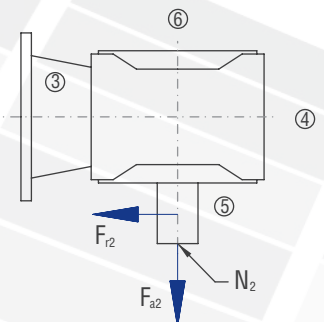

The mass of the gearbox may deviate depending on the flange size, the type and the gear ratio.

Worm gearboxes

# 9.4.9 Type SL 080 – Type S with flange for motor mounting

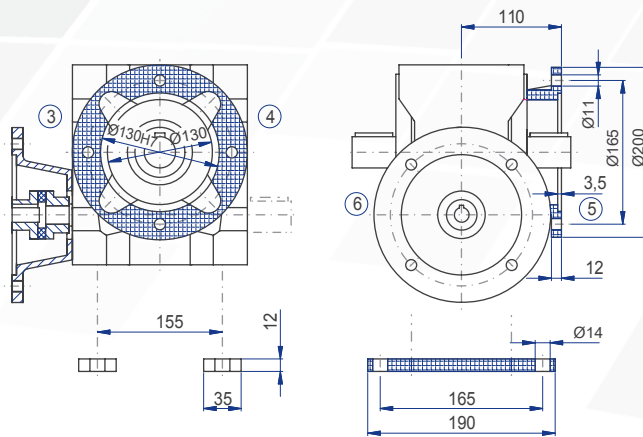
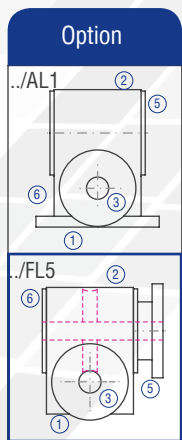
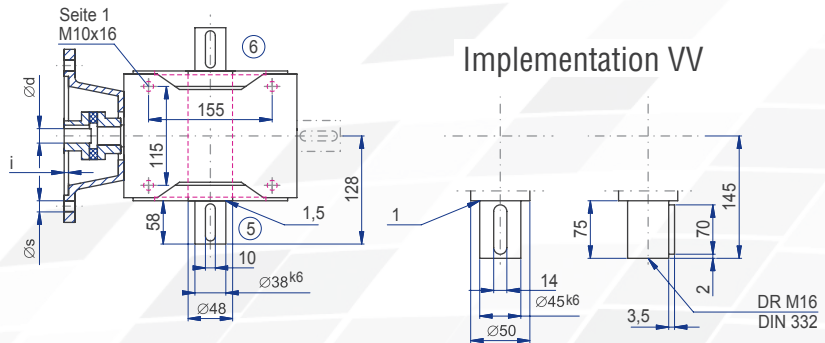
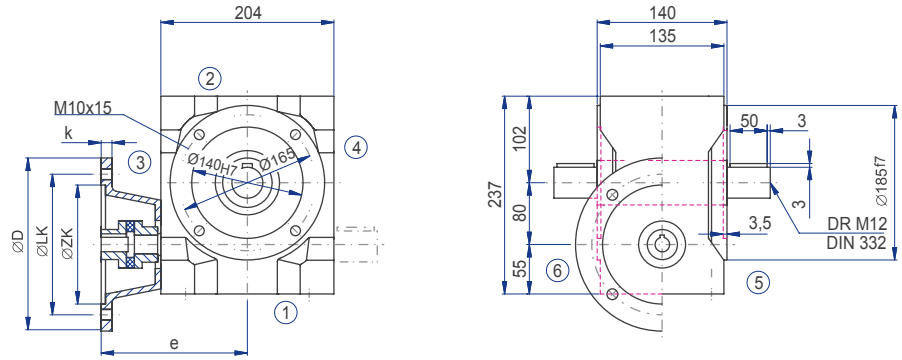
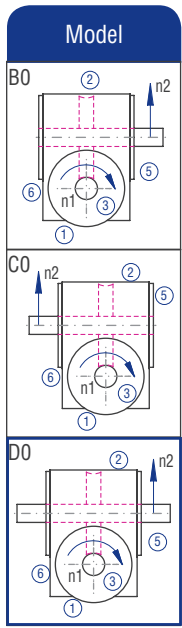

IEC motor	Model	Motor shaft (dxl)	Flange diameter D [mm]	LK [mm]	ZK [mm]	s [mm]	i [mm]	k [mm]	e [mm]
71	B5	14x30	160	130	110	9	4	10	183
80	B14	19x40	160	130	110	9	4	10	183
	B5	19x40	200	165	130	11	4	10	195
90	B14	24x50	160a	130	110	9	4	10	195
	B5	24x50	200	165	130	11	4	10	195
100	B14	28x60	200a	165	130	11	4	20	205
112	B14	28x60	200a	165	130	11	4	20	205

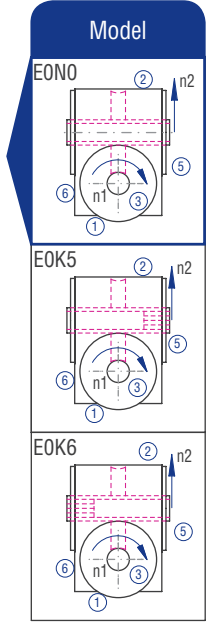
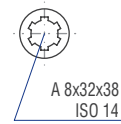
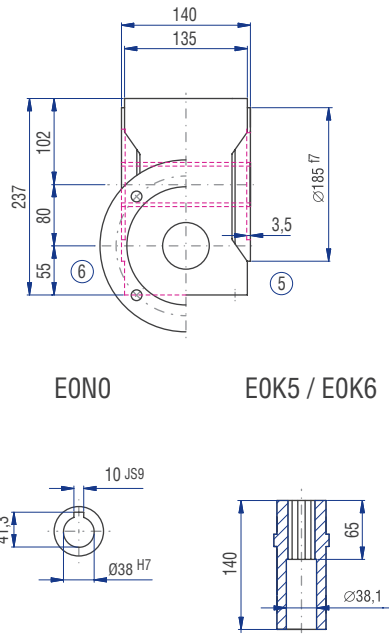
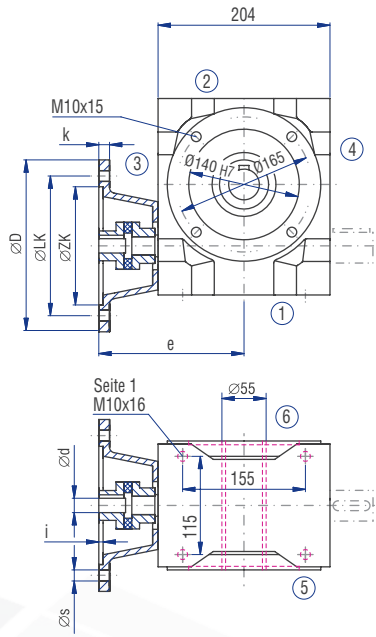

Worm  
gearboxes

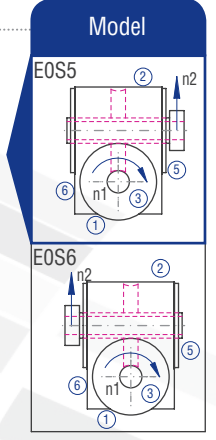
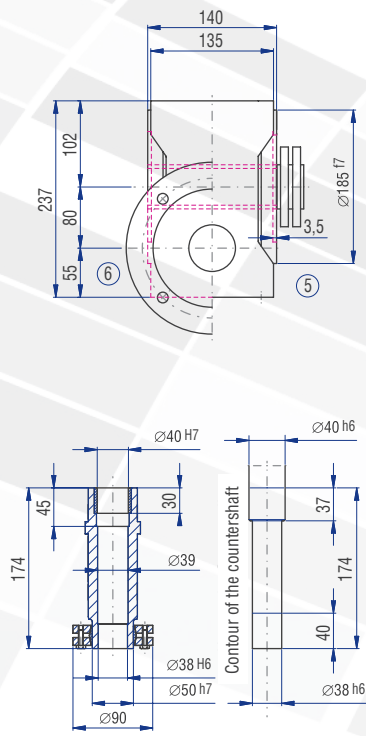
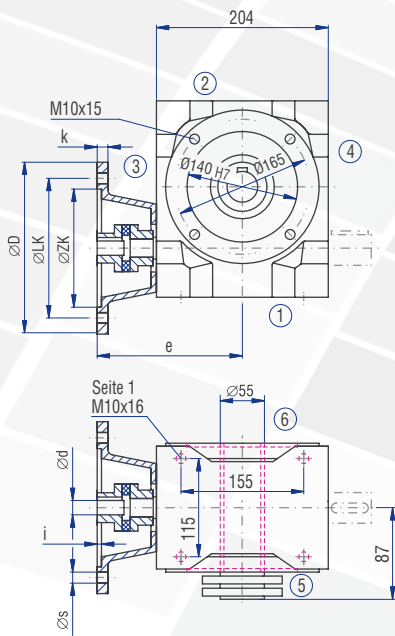

## 9.4.10 Type SL 100 – Type S with flange for motor mounting

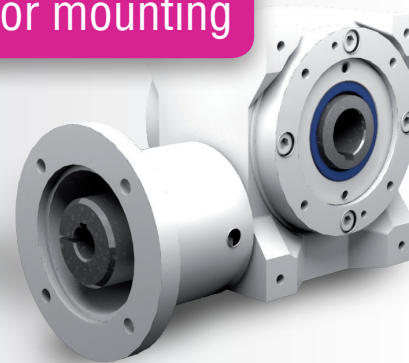

### Characteristics

Characteristic	Standard	Option
<b>Toothing</b>	Hardened and ground worm shaft / bronze worm gear	See chapter 9.2.1
<b>Gear ratio</b>	5:1 to 83:1	
<b>Housing / Flanges</b>	Grey cast iron	
<b>Threaded mounting hole</b>	On gearbox side 1 and on the flanges	See chapter 9.2.3
<b>Shaft</b>	Material 1 C45, shaft ends greased Fit with ISO j6 tolerance with parallel keyway: according to DIN 6885 Sheet 1	See chapter 4.6.2
<b>Hollow shaft</b>	Material 1 C45, shafts greased Fit with ISO H7 tolerance with parallel keyway: according to DIN 6885 Sheet 1	See chapter 4.6.3
<b>Radial shaft seal ring</b>	NBR, form A	See chapter 4.8
<b>Ambient temperature</b>	-10°C to +90°C. The values of the performance tables are valid for 20°C	See chapter 4.9.3
<b>Circumferential backlash</b>	< 30 arcmin	See chapter 9.2.10
<b>Protection class</b>	IP 54	See chapter 4.5
<b>Corrosion protection</b>	Prime coat; layer thickness > 40 µm	See chapter 4.4.1
<b>Bearing life L10h</b>	more than 15,000h	See chapter 4.9.1
<b>Oil change intervals</b>	Not required if the oil temperature is kept below 90°C. The lifetime of the bearings can be increased by the factor 1.5 if the oil is changed after the first 500 service hours and then every 5000 service hours.	See chapter 9.2.8
<b>Lubricants</b>	Synthetic lubricants	See chapter 9.2.8
<b>Flange</b>	Suited for the mounting of IEC motors, models IM B5 and B14	
<b>Coupling</b>	Three-piece claw coupling	

## Performance data

i	i ist		n <sub>1</sub> [1/min]					
			3000	1500	1000	750	500	150
5:1	30:6	n <sub>2</sub> [1/min]	600,0	300,0	200,0	150,0	100,0	30,0
		P <sub>1N</sub> [kW]	29,45	19,31	14,99	12,45	9,47	4,01
		T <sub>2N</sub> [Nm]	450	590	680	745	850	1.150
		P <sub>1NT</sub> [kW]	11,30	8,60	7,55	6,87	5,96	0,00
		Wirkungsgrad	0,96	0,96	0,95	0,94	0,94	0,90
7,5:1	30:4	n <sub>2</sub> [1/min]	400,0	200,0	133,0	100,0	66,0	20,0
		P <sub>1N</sub> [kW]	22,62	14,33	10,92	9,10	7,00	3,03
		T <sub>2N</sub> [Nm]	513	650	743	817	932	1.258
		P <sub>1NT</sub> [kW]	9,06	6,85	5,99	5,43	4,71	0,00
		Wirkungsgrad	0,95	0,95	0,95	0,94	0,93	0,87
10:1	40:4	n <sub>2</sub> [1/min]	300,0	150,0	100,0	75,0	50,0	15,0
		P <sub>1N</sub> [kW]	18,55	11,75	8,95	7,45	5,79	2,02
		T <sub>2N</sub> [Nm]	555	703	803	882	1.006	1.095
		P <sub>1NT</sub> [kW]	8,57	6,35	5,49	4,95	4,30	0,00
		Wirkungsgrad	0,94	0,94	0,94	0,93	0,91	0,85
13:1	52:4	n <sub>2</sub> [1/min]	230,0	115,0	76,0	57,0	38,0	11,0
		P <sub>1N</sub> [kW]	11,09	6,09	4,30	3,37	2,37	0,85
		T <sub>2N</sub> [Nm]	427	464	486	502	523	586
		P <sub>1NT</sub> [kW]	7,87	5,73	4,92	4,43	3,85	0,00
		Wirkungsgrad	0,93	0,92	0,91	0,90	0,89	0,83
15:1	30:2	n <sub>2</sub> [1/min]	200,0	100,0	66,0	50,0	33,0	10,0
		P <sub>1N</sub> [kW]	13,12	8,32	6,41	5,34	4,16	1,88
		T <sub>2N</sub> [Nm]	564	715	817	898	1.025	1.386
		P <sub>1NT</sub> [kW]	5,76	4,31	3,75	3,40	2,95	0,00
		Wirkungsgrad	0,90	0,90	0,89	0,88	0,86	0,77
20:1	40:2	n <sub>2</sub> [1/min]	150,0	75,0	50,0	37,0	25,0	7,5
		P <sub>1N</sub> [kW]	10,84	6,87	5,28	4,45	3,47	1,49
		T <sub>2N</sub> [Nm]	614	778	888	975	1.112	1.441
		P <sub>1NT</sub> [kW]	5,44	3,99	3,44	3,10	2,69	0,00
		Wirkungsgrad	0,89	0,89	0,88	0,86	0,84	0,76
26:1	52:2	n <sub>2</sub> [1/min]	115,0	57,0	38,0	28,0	19,0	5,8
		P <sub>1N</sub> [kW]	7,63	4,20	3,00	2,38	1,72	0,64
		T <sub>2N</sub> [Nm]	556	605	634	655	683	773
		P <sub>1NT</sub> [kW]	4,94	3,57	3,06	2,75	2,40	0,00
		Wirkungsgrad	0,88	0,87	0,85	0,83	0,80	0,73
30:1	30:1	n <sub>2</sub> [1/min]	100,0	50,0	33,0	25,0	16,0	5,0
		P <sub>1N</sub> [kW]	7,53	4,78	3,60	3,19	2,51	1,18
		T <sub>2N</sub> [Nm]	590	748	825	950	1.080	1.437
		P <sub>1NT</sub> [kW]	3,50	2,60	2,27	2,06	1,81	0,00
		Wirkungsgrad	0,82	0,82	0,80	0,78	0,75	0,64
40:1	40:1	n <sub>2</sub> [1/min]	75,0	37,0	25,0	18,0	12,0	3,8
		P <sub>1N</sub> [kW]	6,33	4,01	3,13	2,65	2,13	1,00
		T <sub>2N</sub> [Nm]	645	817	933	1.025	1.169	1.581
		P <sub>1NT</sub> [kW]	3,32	2,42	2,09	1,90	1,67	0,00
		Wirkungsgrad	0,80	0,80	0,78	0,76	0,72	0,62
53:1	52:1	n <sub>2</sub> [1/min]	57,0	28,0	18,0	14,0	9,4	2,8
		P <sub>1N</sub> [kW]	4,76	2,63	1,92	1,53	1,11	0,45
		T <sub>2N</sub> [Nm]	615	670	704	728	762	870
		P <sub>1NT</sub> [kW]	3,04	2,19	1,88	1,71	1,51	0,00
		Wirkungsgrad	0,78	0,77	0,74	0,72	0,69	0,59
62:1	63:1	n <sub>2</sub> [1/min]	48,0	24,0	16,0	12,0	8,1	2,4
		P <sub>1N</sub> [kW]	4,59	2,91	2,17	1,70	1,21	0,44
		T <sub>2N</sub> [Nm]	645	817	886	886	886	886
		P <sub>1NT</sub> [kW]	2,39	1,74	1,52	1,39	1,24	0,00
		Wirkungsgrad	0,70	0,70	0,68	0,65	0,61	0,50
83:1	82:1	n <sub>2</sub> [1/min]	36,0	18,0	12,0	9,0	6,0	1,8
		P <sub>1N</sub> [kW]	3,33	1,74	1,23	0,94	0,67	0,24
		T <sub>2N</sub> [Nm]	591	599	599	599	599	599
		P <sub>1NT</sub> [kW]	2,24	1,61	1,40	1,28	1,15	0,00
		Wirkungsgrad	0,68	0,66	0,62	0,61	0,57	0,47

	5:1	7,5:1	10:1	13:1	15:1	20:1	26:1	30:1	40:1	53:1	62:1	83:1
T <sub>2max</sub> [Nm]	1190	1360	1090	736	1610	1440	980	1765	1582	1080	1040	1000

## Permissible radial force F<sub>r2</sub> and axial force F<sub>a2</sub> on shaft N<sub>2</sub>

n <sub>2</sub> [rpm]	200		125		75		50		30		10	
	F <sub>r</sub> [N]	F <sub>a</sub> [N]	F <sub>r</sub> [N]	F <sub>a</sub> [N]	F <sub>r</sub> [N]	F <sub>a</sub> [N]	F <sub>r</sub> [N]	F <sub>a</sub> [N]	F <sub>r</sub> [N]	F <sub>a</sub> [N]	F <sub>r</sub> [N]	F <sub>a</sub> [N]
< 800	3650	1825	4000	2000	4750	2375	5600	2800	6700	3350	9500	4750
> 800	2920	1460	3200	1600	3800	1900	4480	2240	5360	2680	7600	3800

## Inertia moments/mass

Inertia moment J<sub>1</sub> related to the fast-rotating shaft (N<sub>1</sub>)

J <sub>1</sub>	Inertia moment [kgcm <sup>2</sup> ]											
	5:1	7,5:1	10:1	13:1	15:1	20:1	26:1	30:1	40:1	53:1	62:1	83:1
J <sub>1</sub>	30.63	26.13	22.28	20.53	23.42	20.62	19.59	22.75	20.21	19.35	20.81	19.59

Mass ca. [kg]
55

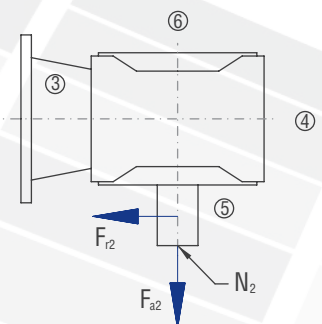

The mass of the gearbox may deviate depending on the flange size, the type and the gear ratio.

Worm gearboxes

# 9.4.10 Type SL 100 – Type S with flange for motor mounting

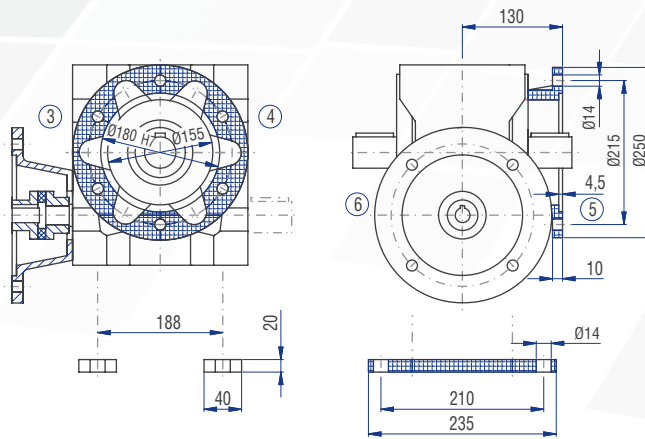
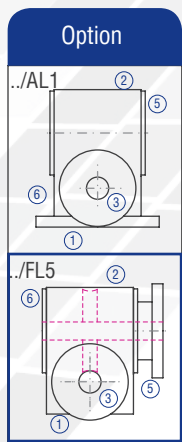
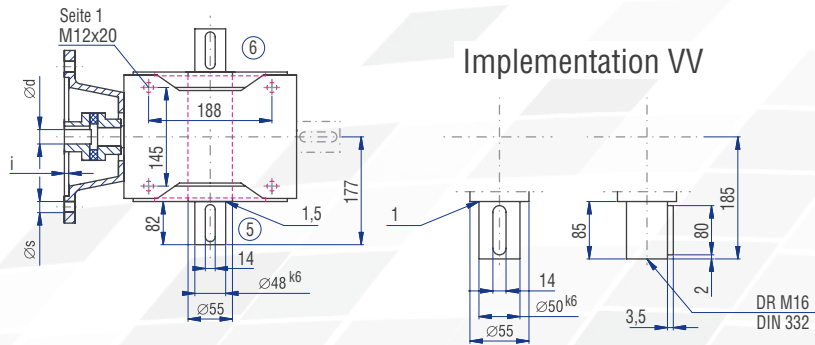
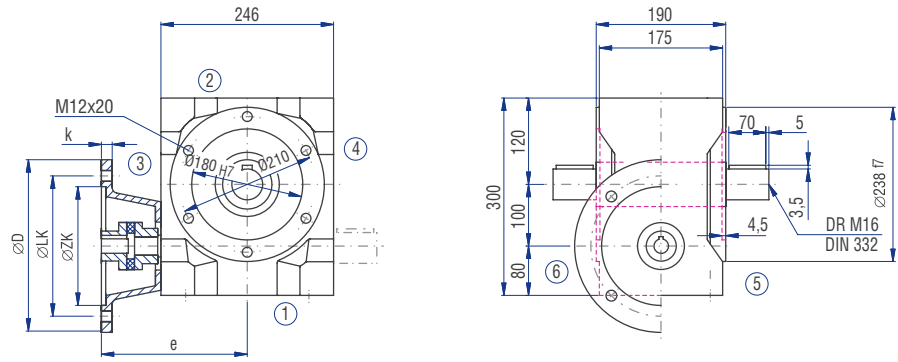
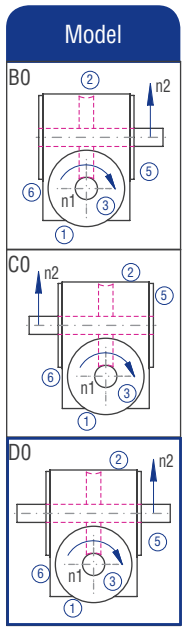

IEC motor	Model	Motor shaft (d x l)	Flange diameter D [mm]	LK [mm]	ZK [mm]	s [mm]	i [mm]	k [mm]	e [mm]
90	B5	24x50	200	165	130	M10	4	18	235
100	B5	28x60	250	215	180	14	5	18	245
112	B5	28x60	250	215	180	14	5	18	245
132	B5	38x80	300	265	230	14	5	18	265



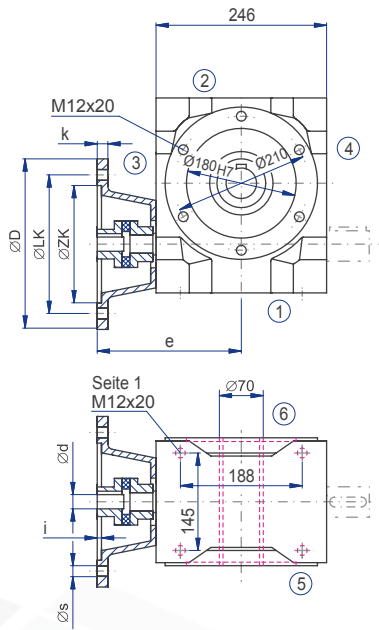

E0N0

E0K5 / E0K6

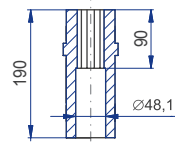
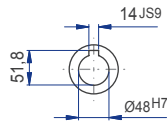

A 8x42x48  
ISO 14

Model

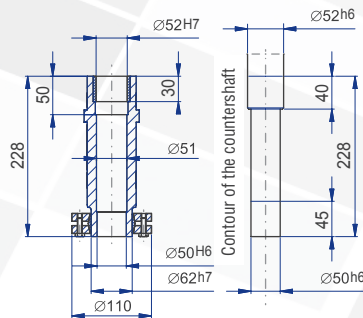
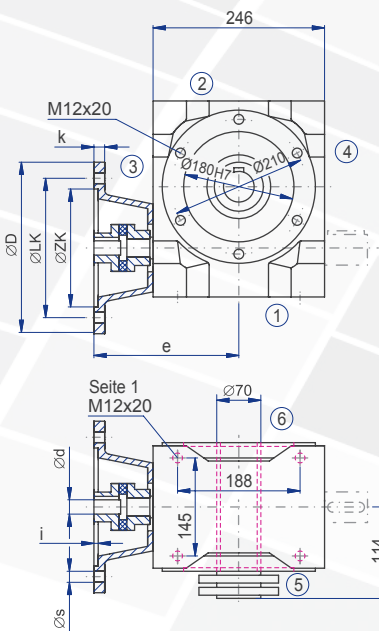
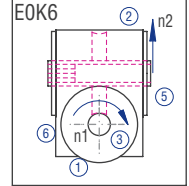
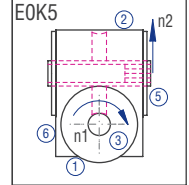
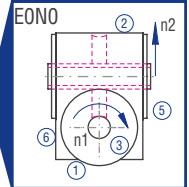

Model

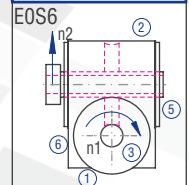
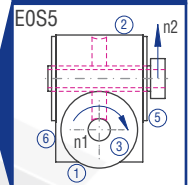

Worm  
gearboxes



### Characteristics

Characteristic	Standard	Option
<b>Toothing</b>	Hardened and ground worm shaft / bronze worm gear	See chapter 9.2.1
<b>Gear ratio</b>	5:1 to 83:1	
<b>Housing / Flanges</b>	Grey cast iron	
<b>Threaded mounting hole</b>	On gearbox sides 1, 2 and on the flanges	See chapter 9.2.3
<b>Shaft</b>	Material 1 C45, shaft ends greased Fit with ISO j6 tolerance with parallel keyway: according to DIN 6885 Sheet 1	See chapter 4.6.2
<b>Hollow shaft</b>	Material: GGG grey cast iron; shafts greased Fit with ISO H7 tolerance with parallel keyway: according to DIN 6885 Sheet 1	See chapter 4.6.3
<b>Radial shaft seal ring</b>	NBR, form A	See chapter 4.8
<b>Ambient temperature</b>	-10°C to +90°C. The values of the performance tables are valid for 20°C	See chapter 4.9.3
<b>Circumferential backlash</b>	< 30 arcmin	See chapter 9.2.10
<b>Protection class</b>	IP 54	See chapter 4.5
<b>Corrosion protection</b>	Prime coat; layer thickness > 40 µm	See chapter 4.4.1
<b>Bearing life L10h</b>	more than 15,000h	See chapter 4.9.1
<b>Oil change intervals</b>	Not required if the oil temperature is kept below 90°C. The lifetime of the bearings can be increased by the factor 1.5 if the oil is changed after the first 500 service hours and then every 5000 service hours.	See chapter 9.2.8
<b>Lubricants</b>	Synthetic lubricants	See chapter 9.2.8
<b>Flange</b>	Suited for the mounting of IEC motors, models IM B5 and B14	
<b>Coupling</b>	Three-piece claw coupling	

## Performance data

i	i ist		n <sub>1</sub> [rpm]					
			3000	1500	1000	750	500	150
5:1	29:6	n <sub>2</sub> [rpm]	600.0	300.0	200.0	150.0	100.0	30.0
		P <sub>1N</sub> [kW]	42.41	30.32	23.15	19.34	14.72	6.29
		T <sub>2N</sub> [Nm]	626	895	1,025	1,130	1,290	1,760
		P <sub>1NT</sub> [kW]	17.93	14.48	13.01	11.94	10.40	0.00
		Efficiency	0.96	0.96	0.96	0.95	0.95	0.91
7.5:1	29:4	n <sub>2</sub> [rpm]	400.0	200.0	133.0	100.0	66.0	20.0
		P <sub>1N</sub> [kW]	35.71	22.49	17.13	14.13	11.03	4.96
		T <sub>2N</sub> [Nm]	738	986	1,127	1,239	1,436	2,016
		P <sub>1NT</sub> [kW]	14.40	11.53	10.31	9.44	8.20	0.00
		Efficiency	0.95	0.95	0.95	0.95	0.94	0.88
10:1	40:4	n <sub>2</sub> [rpm]	300.0	150.0	100.0	75.0	50.0	15.0
		P <sub>1N</sub> [kW]	28.41	17.86	13.61	11.22	8.62	3.78
		T <sub>2N</sub> [Nm]	850	1,069	1,222	1,343	1,532	2,092
		P <sub>1NT</sub> [kW]	13.62	10.68	9.41	8.54	7.37	0.00
		Efficiency	0.94	0.94	0.94	0.94	0.93	0.87
13:1	52:4	n <sub>2</sub> [rpm]	230.0	115.0	76.0	57.0	38.0	11.0
		P <sub>1N</sub> [kW]	18.19	10.02	7.00	5.42	3.86	1.37
		T <sub>2N</sub> [Nm]	700	763	800	826	862	966
		P <sub>1NT</sub> [kW]	12.83	9.84	8.56	7.72	6.65	0.00
		Efficiency	0.93	0.92	0.92	0.92	0.90	0.85
15:1	29:2	n <sub>2</sub> [rpm]	200.0	100.0	66.0	50.0	33.0	10.0
		P <sub>1N</sub> [kW]	20.06	12.61	10.01	8.88	6.91	3.21
		T <sub>2N</sub> [Nm]	862	1,084	1,290	1,510	1,743	2,423
		P <sub>1NT</sub> [kW]	9.13	7.24	6.44	5.88	5.10	0.00
		Efficiency	0.90	0.90	0.90	0.89	0.88	0.79
20:1	40:2	n <sub>2</sub> [rpm]	150.0	75.0	50.0	37.0	25.0	7.5
		P <sub>1N</sub> [kW]	16.59	10.44	7.95	6.74	5.23	2.33
		T <sub>2N</sub> [Nm]	940	1,183	1,352	1,510	1,717	2,310
		P <sub>1NT</sub> [kW]	8.61	6.68	5.86	5.31	4.58	0.00
		Efficiency	0.89	0.89	0.89	0.88	0.86	0.78
26:1	52:2	n <sub>2</sub> [rpm]	115.0	57.0	38.0	28.0	19.0	5.8
		P <sub>1N</sub> [kW]	12.76	7.03	4.97	3.90	2.78	1.04
		T <sub>2N</sub> [Nm]	929	1,012	1,062	1,097	1,146	1,294
		P <sub>1NT</sub> [kW]	8.09	6.14	5.32	4.80	4.14	0.00
		Efficiency	0.88	0.87	0.86	0.85	0.83	0.75
30:1	30:1	n <sub>2</sub> [rpm]	100.0	50.0	33.0	25.0	16.0	5.0
		P <sub>1N</sub> [kW]	11.76	7.49	6.38	5.65	4.52	1.86
		T <sub>2N</sub> [Nm]	901	1,134	1,448	1,690	1,952	2,270
		P <sub>1NT</sub> [kW]	5.50	4.31	3.83	3.51	3.08	0.00
		Efficiency	0.83	0.82	0.82	0.81	0.78	0.66
40:1	40:1	n <sub>2</sub> [rpm]	75.0	37.0	25.0	18.0	12.0	3.8
		P <sub>1N</sub> [kW]	9.57	6.10	4.81	4.25	3.35	1.42
		T <sub>2N</sub> [Nm]	987	1,242	1,470	1,690	1,922	2,310
		P <sub>1NT</sub> [kW]	5.22	4.00	3.52	3.20	2.79	0.00
		Efficiency	0.81	0.80	0.80	0.78	0.75	0.64
53:1	52:1	n <sub>2</sub> [rpm]	57.0	28.0	18.0	14.0	9.4	2.8
		P <sub>1N</sub> [kW]	7.93	4.44	3.15	2.48	1.83	0.73
		T <sub>2N</sub> [Nm]	1,037	1,132	1,189	1,230	1,289	1,470
		P <sub>1NT</sub> [kW]	4.93	3.71	3.23	2.93	2.56	0.00
		Efficiency	0.79	0.77	0.76	0.75	0.71	0.61
62:1	62:1	n <sub>2</sub> [rpm]	48.0	24.0	16.0	12.0	8.1	2.4
		P <sub>1N</sub> [kW]	6.86	4.37	3.38	2.87	2.25	0.84
		T <sub>2N</sub> [Nm]	988	1,243	1,421	1,562	1,731	1,731
		P <sub>1NT</sub> [kW]	3.75	2.86	2.52	2.32	2.05	0.00
		Efficiency	0.73	0.72	0.71	0.69	0.65	0.52
83:1	83:1	n <sub>2</sub> [rpm]	36.0	18.0	12.0	9.0	6.0	1.8
		P <sub>1N</sub> [kW]	5.72	3.30	2.23	1.73	1.23	0.46
		T <sub>2N</sub> [Nm]	1,043	1,167	1,167	1,167	1,167	1,167
		P <sub>1NT</sub> [kW]	3.55	2.66	2.33	2.13	1.89	0.00
		Efficiency	0.69	0.67	0.66	0.64	0.60	0.48

	5:1	7.5:1	10:1	13:1	15:1	20:1	26:1	30:1	40:1	53:1	62:1	83:1
T <sub>2max</sub> [Nm]	2250	2250	2250	1190	2250	2392	1630	2270	2320	1810	2010	1950

## Permissible radial force F<sub>r2</sub> and axial force F<sub>a2</sub> on shaft N<sub>2</sub>

n <sub>2</sub> [rpm]	200		125		75		50		30		10	
	F <sub>r</sub> [N]	F <sub>a</sub> [N]	F <sub>r</sub> [N]	F <sub>a</sub> [N]	F <sub>r</sub> [N]	F <sub>a</sub> [N]	F <sub>r</sub> [N]	F <sub>a</sub> [N]	F <sub>r</sub> [N]	F <sub>a</sub> [N]	F <sub>r</sub> [N]	F <sub>a</sub> [N]
< 1300	4700	2350	5300	2650	6300	3150	7500	3750	9000	4500	11000	5500
> 1300	3760	1880	4240	2120	5040	2520	6000	3000	7200	3600	8800	4400

## Inertia moments/mass

Inertia moment J<sub>1</sub> related to the fast-rotating shaft (N<sub>1</sub>)

J <sub>1</sub>	Inertia moment [kgcm <sup>2</sup> ]											
	5:1	7.5:1	10:1	13:1	15:1	20:1	26:1	30:1	40:1	53:1	62:1	83:1
J <sub>1</sub>	50.02	43.96	34.83	30.79	40.32	32.18	28.96	39.42	31.51	28.50	33.31	29.29

Mass ca. [kg]
85

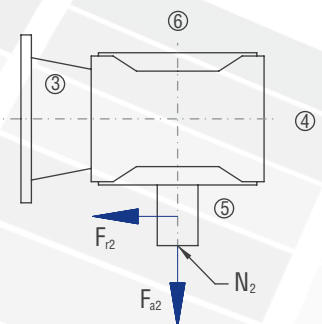

The mass of the gearbox may deviate depending on the flange size, the type and the gear ratio.

## 9.4.11 Type SL 125 – Type S with flange for motor mounting

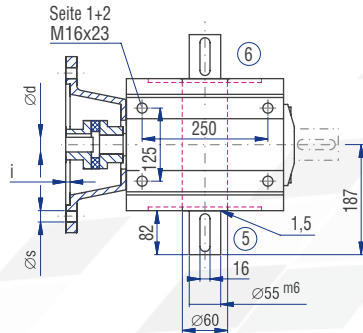
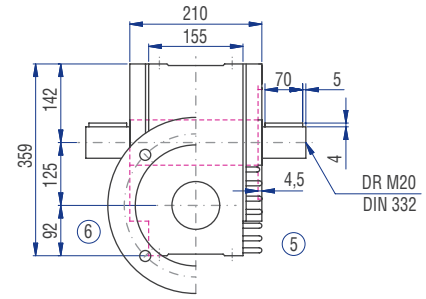
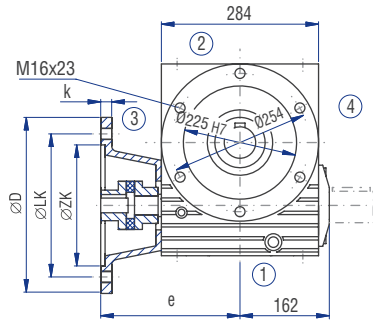
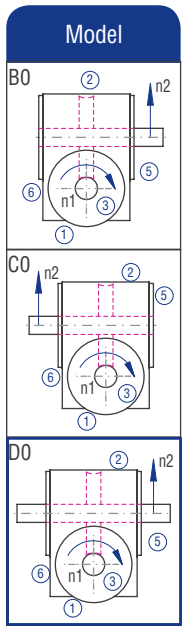

### Implementation VV

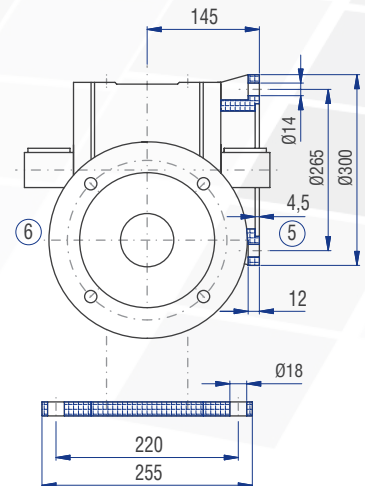
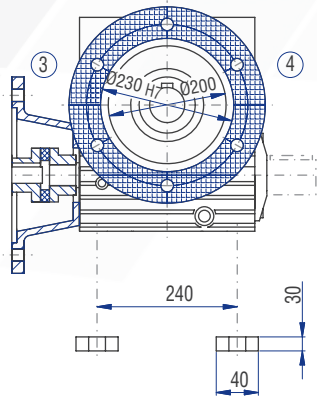
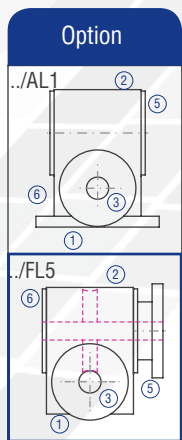
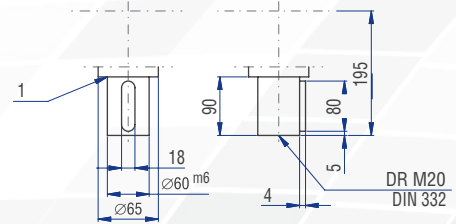

IEC motor	Model	Motor shaft (dxl)	Flange diameter D [mm]	LK [mm]	ZK [mm]	s [mm]	i [mm]	k [mm]	e [mm]
90	B5	24x50	200	165	130	M10	4	18	257
100	B5	28x60	250	215	180	14	5	18	267
112	B5	28x60	250	215	180	14	5	18	267
132	B5	38x80	300	265	230	14	5	18	287
160	B5	42x110	350	300	250	18	6	18	327

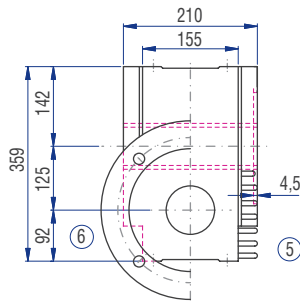
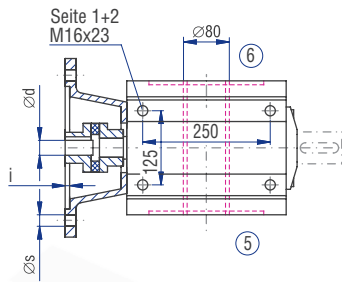
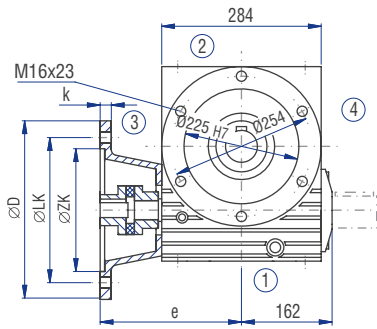

E0N0

E0K5 / E0K6

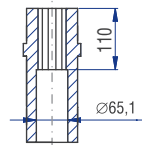
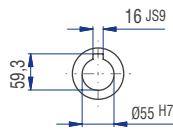

A 8x56x65  
ISO 14

Model

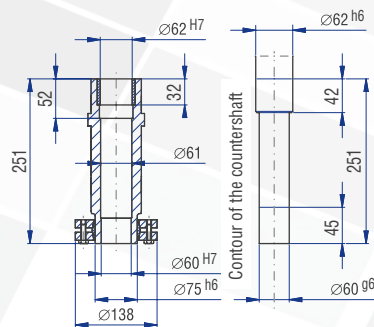
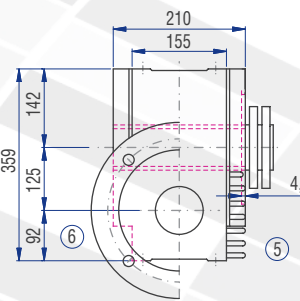
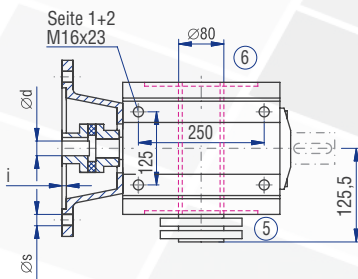
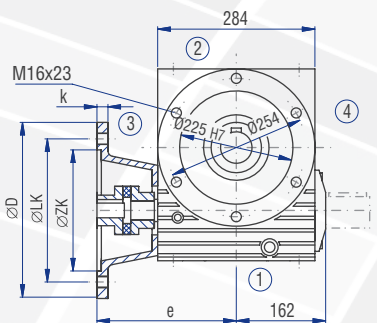
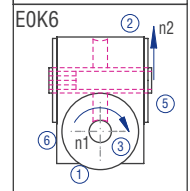
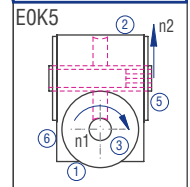
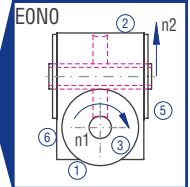

Model

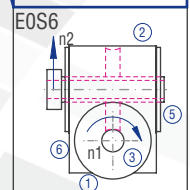
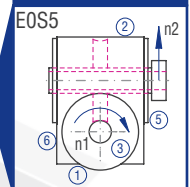

Worm  
gearboxes

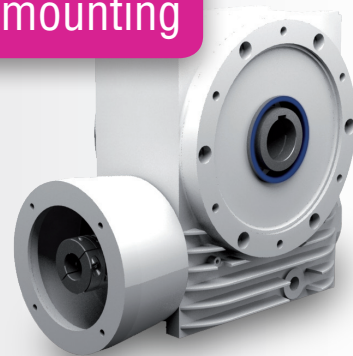

### Characteristics

Characteristic	Standard	Option
<b>Toothing</b>	Hardened and ground worm shaft / bronze worm gear	See chapter 9.2.1
<b>Gear ratio</b>	5:1 to 83:1	
<b>Housing / Flanges</b>	Grey cast iron	
<b>Threaded mounting hole</b>	On gearbox sides 1, 2 and on the flanges	See chapter 9.2.3
<b>Shaft</b>	Material 1 C45, shaft ends greased Fit with ISO j6 tolerance with parallel keyway: according to DIN 6885 Sheet 1	See chapter 4.6.2
<b>Hollow shaft</b>	Material: GGG grey cast iron; shafts greased Fit with ISO H7 tolerance with parallel keyway: according to DIN 6885 Sheet 1	See chapter 4.6.3
<b>Radial shaft seal ring</b>	NBR, form A	See chapter 4.8
<b>Ambient temperature</b>	-10°C to +90°C. The values of the performance tables are valid for 20°C	See chapter 4.9.3
<b>Circumferential backlash</b>	< 30 arcmin	See chapter 9.2.10
<b>Protection class</b>	IP 54	See chapter 4.5
<b>Corrosion protection</b>	Prime coat; layer thickness > 40 µm	See chapter 4.4.1
<b>Bearing life L10h</b>	more than 15,000h	See chapter 4.9.1
<b>Oil change intervals</b>	Not required if the oil temperature is kept below 90°C. The lifetime of the bearings can be increased by the factor 1.5 if the oil is changed after the first 500 service hours and then every 5000 service hours.	See chapter 9.2.8
<b>Lubricants</b>	Synthetic lubricants	See chapter 9.2.8
<b>Flange</b>	Suited for the mounting of IEC motors, models IM B5 and B14	
<b>Coupling</b>	Three-piece claw coupling	



## Performance data

i	i ist		n <sub>1</sub> [rpm]					
			3000	1500	1000	750	500	150
5:1	30:6	n <sub>2</sub> [rpm]	300.0	200.0	150.0	100.0	75.0	30.0
		P <sub>1N</sub> [kW]	53.11	40.37	33.38	24.58	9.96	
		T <sub>2N</sub> [Nm]	1,640	1,870	2,040	2,230	2,950	
		P <sub>1NT</sub> [kW]	25.20	23.42	21.89	19.33	0.00	
		Efficiency	0.97	0.97	0.96	0.95	0.93	
7.5:1	30:4	n <sub>2</sub> [rpm]	400.0	200.0	133.0	100.0	66.0	20.0
		P <sub>1N</sub> [kW]	43.91	39.53	29.83	24.94	20.05	9.34
		T <sub>2N</sub> [Nm]	996	1,793	2,051	2,263	2,729	4,013
		P <sub>1NT</sub> [kW]	23.14	20.07	18.56	17.28	15.18	0.00
		Efficiency	0.95	0.95	0.96	0.95	0.95	0.90
10:1	40:4	n <sub>2</sub> [rpm]	300.0	150.0	100.0	75.0	50.0	15.0
		P <sub>1N</sub> [kW]	51.25	32.26	24.59	20.28	15.60	6.98
		T <sub>2N</sub> [Nm]	1,550	1,951	2,231	2,453	2,800	3,909
		P <sub>1NT</sub> [kW]	22.09	18.76	17.04	15.66	13.57	0.00
		Efficiency	0.95	0.95	0.95	0.95	0.94	0.88
13:1	54:4	n <sub>2</sub> [rpm]	230.0	115.0	76.0	57.0	38.0	11.0
		P <sub>1N</sub> [kW]	36.29	19.80	13.87	10.87	7.66	2.73
		T <sub>2N</sub> [Nm]	1,466	1,600	1,681	1,738	1,810	2,041
		P <sub>1NT</sub> [kW]	20.77	17.24	15.41	14.02	12.06	0.00
		Efficiency	0.94	0.94	0.94	0.93	0.92	0.87
15:1	30:2	n <sub>2</sub> [rpm]	200.0	100.0	66.0	50.0	33.0	10.0
		P <sub>1N</sub> [kW]	29.82	22.42	18.10	16.22	12.88	6.17
		T <sub>2N</sub> [Nm]	1,310	1,970	2,386	2,820	3,320	4,830
		P <sub>1NT</sub> [kW]	14.64	12.55	11.55	10.73	9.40	0.00
		Efficiency	0.92	0.92	0.92	0.91	0.90	0.82
20:1	40:2	n <sub>2</sub> [rpm]	150.0	75.0	50.0	37.0	25.0	7.5
		P <sub>1N</sub> [kW]	29.60	18.83	14.35	12.43	9.80	4.49
		T <sub>2N</sub> [Nm]	1,715	2,158	2,467	2,850	3,294	4,576
		P <sub>1NT</sub> [kW]	13.95	11.70	10.58	9.70	8.39	0.00
		Efficiency	0.91	0.90	0.90	0.90	0.88	0.80

	5:1	7.5:1	10:1	13:1	15:1	20:1	26:1	30:1	40:1	53:1	62:1	83:1
T <sub>2max</sub> [Nm]	4450	4450	4780	2410	4550	5050	3345	4500	5120	3700	3900	4050

Worm  
gearboxes

## Permissible radial force F<sub>r2</sub> and axial force F<sub>a2</sub> on shaft N<sub>2</sub>

n <sub>2</sub> [rpm]	200		125		75		50		30		10	
	F <sub>r</sub> [N]	F <sub>a</sub> [N]	F <sub>r</sub> [N]	F <sub>a</sub> [N]	F <sub>r</sub> [N]	F <sub>a</sub> [N]	F <sub>r</sub> [N]	F <sub>a</sub> [N]	F <sub>r</sub> [N]	F <sub>a</sub> [N]	F <sub>r</sub> [N]	F <sub>a</sub> [N]
< 2300	5600	2800	6800	3400	7600	3800	8600	4300	10200	5100	13600	6800
> 2300	4670	2335	5670	2835	6330	3165	7170	3585	8500	4250	11300	5650

## Inertia moments/mass

Inertia moment J<sub>1</sub> related to the fast-rotating shaft (N<sub>1</sub>)

J <sub>1</sub>	Inertia moment [kgcm <sup>2</sup> ]											
	5:1	7.5:1	10:1	13:1	15:1	20:1	26:1	30:1	40:1	53:1	62:1	83:1
J <sub>1</sub>	176.14	137.49	97.13	75.81	114.31	84.22	71.53	108.51	80.99	70.50	86.78	72.75

Mass  
ca. [kg]  
157

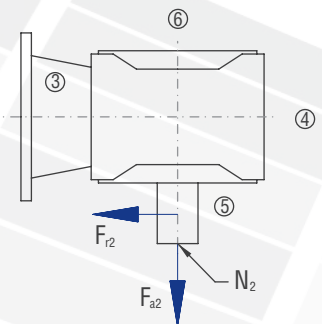

The mass of the gearbox may deviate depending on the flange size, the type and the gear ratio.

# 9.4.12 Type SL 160 – Type S with flange for motor mounting

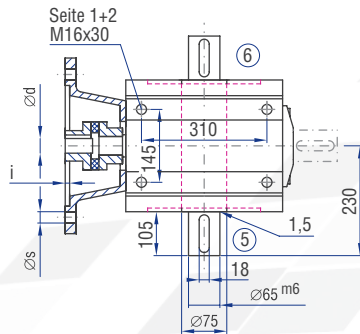
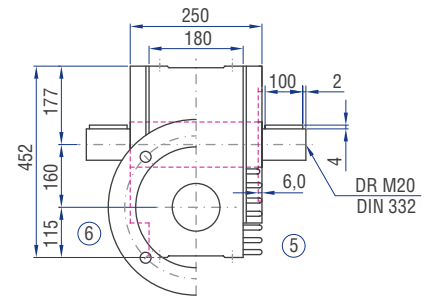
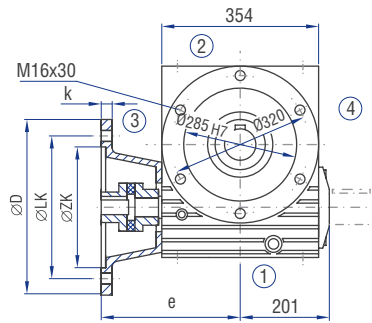
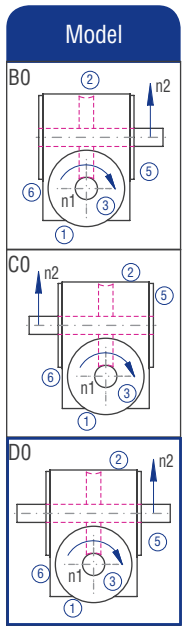

## Implementation VV

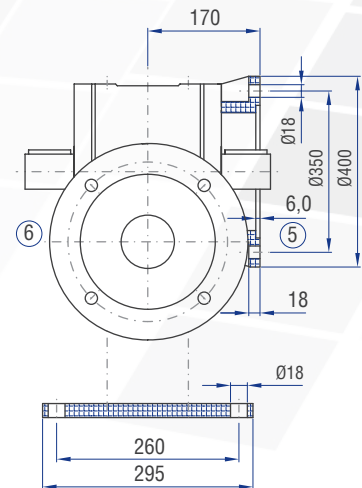
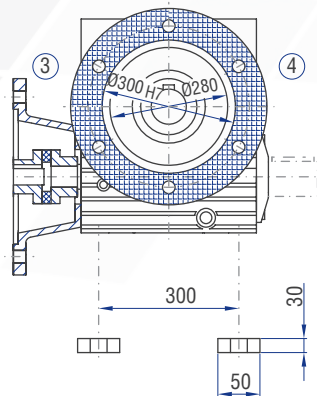
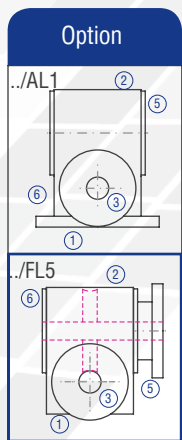
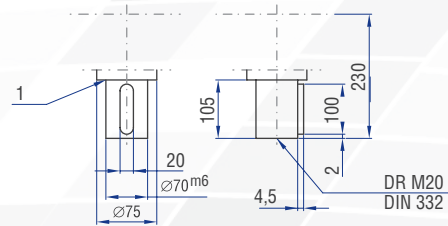

IEC motor	Model	Motor shaft (dxl)	Flange diameter D [mm]	LK [mm]	ZK [mm]	s [mm]	i [mm]	k [mm]	e [mm]
100	B5	28x60	250	215	180	M12	5	18	310
112	B5	28x60	250	215	180	M12	5	18	310
132	B5	38x80	300	265	230	14	5	18	340
160	B5	42x110	350	300	250	18	6	18	370
180	B5	48x110	350	300	250	18	6	18	370

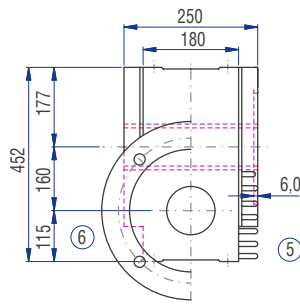
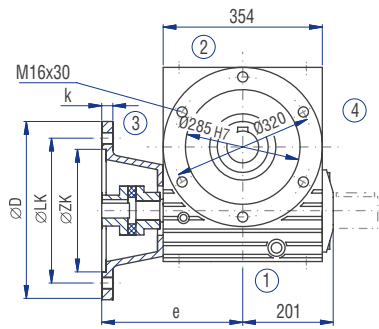

E0N0

E0K5 / E0K6

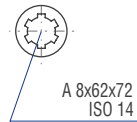
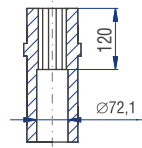
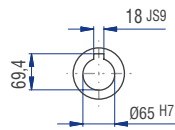
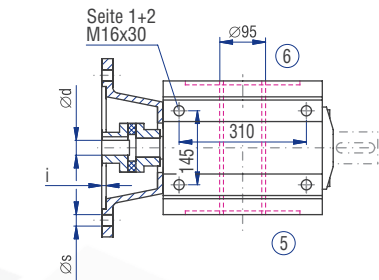

Model

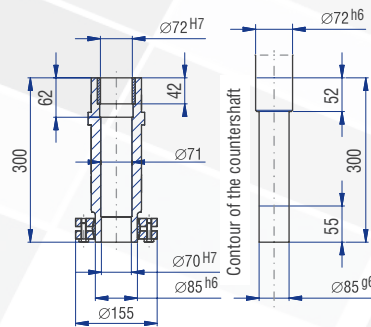
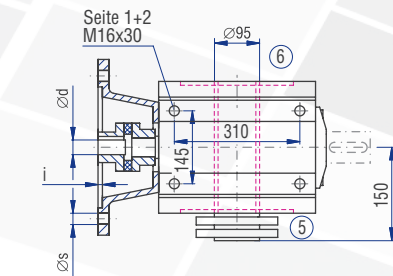
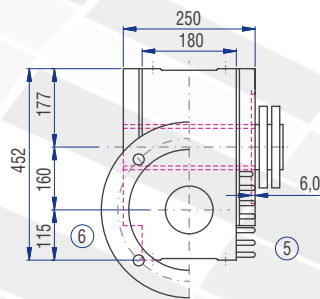
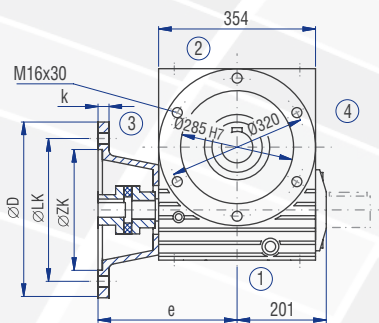
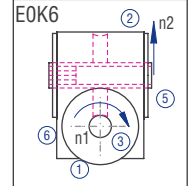
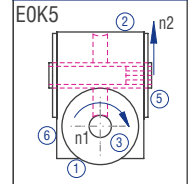
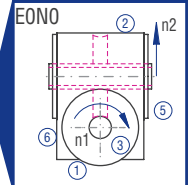

Model

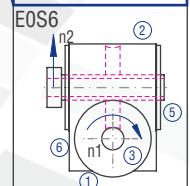
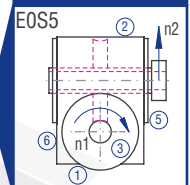

Worm  
gearboxes

## 9.4.13 Type SL 200 – Type S with flange for motor mounting



### Characteristics

Characteristic	Standard	Option
<b>Toothing</b>	Hardened and ground worm shaft / bronze worm gear	See chapter 9.2.1
<b>Gear ratio</b>	5:1 to 83:1	
<b>Housing / Flanges</b>	Grey cast iron	
<b>Threaded mounting hole</b>	On gearbox sides 1, 2 and on the flanges	See chapter 9.2.3
<b>Shaft</b>	Material 1 C45, shaft ends greased Fit with ISO j6 tolerance with parallel keyway: according to DIN 6885 Sheet 1	See chapter 4.6.2
<b>Hollow shaft</b>	Material: GGG grey cast iron; shafts greased Fit with ISO H7 tolerance with parallel keyway: according to DIN 6885 Sheet 1	See chapter 4.6.3
<b>Radial shaft seal ring</b>	NBR, form A	See chapter 4.8
<b>Ambient temperature</b>	-10°C to +90°C. The values of the performance tables are valid for 20°C	See chapter 4.9.3
<b>Circumferential backlash</b>	< 30 arcmin	See chapter 9.2.10
<b>Protection class</b>	IP 54	See chapter 4.5
<b>Corrosion protection</b>	Prime coat; layer thickness > 40 µm	See chapter 4.4.1
<b>Bearing life L10h</b>	more than 15,000h	See chapter 4.9.1
<b>Oil change intervals</b>	Not required if the oil temperature is kept below 90°C. The lifetime of the bearings can be increased by the factor 1.5 if the oil is changed after the first 500 service hours and then every 5000 service hours.	See chapter 9.2.8
<b>Lubricants</b>	Synthetic lubricants	See chapter 9.2.8
<b>Flange</b>	Suited for the mounting of IEC motors, models IM B5 and B14	
<b>Coupling</b>	Three-piece claw coupling	

## Performance data

i	i ist		n <sub>1</sub> [rpm]					
			3000	1500	1000	750	500	150
5:1	30:6	n <sub>2</sub> [rpm]	300.0	200.0	150.0	100.0	75.0	30.0
		P <sub>1N</sub> [kW]	84.20	64.77	55.30	41.45	18.05	
		T <sub>2N</sub> [Nm]	260	3,000	3,380	3,800	5,400	
		P <sub>1NT</sub> [kW]	41.80	40.25	38.36	34.49	0.00	
		Efficiency	0.97	0.97	0.96	0.96	0.94	
7.5:1	30:4	n <sub>2</sub> [rpm]	200.0	133.0	100.0	66.0	20.0	
		P <sub>1N</sub> [kW]	62.59	50.68	44.55	36.26	17.32	
		T <sub>2N</sub> [Nm]	2,869	3,485	4,084	4,987	7,607	
		P <sub>1NT</sub> [kW]	33.51	32.09	30.44	27.20	0.00	
		Efficiency	0.96	0.96	0.96	0.96	0.92	
10:1	40:4	n <sub>2</sub> [rpm]	150.0	100.0	75.0	50.0	15.0	
		P <sub>1N</sub> [kW]	50.86	38.38	32.92	26.73	12.45	
		T <sub>2N</sub> [Nm]	3,076	3,519	4,024	4,851	7,134	
		P <sub>1NT</sub> [kW]	30.91	29.22	27.42	24.16	0.00	
		Efficiency	0.95	0.96	0.96	0.95	0.90	
13:1	53:4	n <sub>2</sub> [rpm]	230.0	115.0	76.0	57.0	38.0	11.0
		P <sub>1N</sub> [kW]	64.74	40.74	31.06	24.46	17.27	6.24
		T <sub>2N</sub> [Nm]	2,594	3,265	3,734	3,921	4,109	4,633
		P <sub>1NT</sub> [kW]	31.35	28.70	26.62	24.63	21.36	0.00
		Efficiency	0.95	0.95	0.95	0.95	0.94	0.88
15:1	30:2	n <sub>2</sub> [rpm]	100.0	66.0	50.0	33.0	10.0	
		P <sub>1N</sub> [kW]	39.27	32.34	28.88	23.23	11.50	
		T <sub>2N</sub> [Nm]	3,450	4,308	5,130	6,122	9,244	
		P <sub>1NT</sub> [kW]	20.99	20.00	18.92	16.85	0.00	
		Efficiency	0.92	0.93	0.93	0.92	0.84	
20:1	40:2	n <sub>2</sub> [rpm]	150.0	75.0	50.0	37.0	25.0	7.5
		P <sub>1N</sub> [kW]	42.29	29.60	24.14	21.62	17.17	8.22
		T <sub>2N</sub> [Nm]	2,450	3,430	4,241	5,010	5,902	8,587
		P <sub>1NT</sub> [kW]	20.87	19.21	18.07	16.92	14.86	0.00
		Efficiency	0.91	0.91	0.92	0.91	0.90	0.82
26:1	53:2	n <sub>2</sub> [rpm]	115.0	57.0	38.0	28.0	19.0	5.8
		P <sub>1N</sub> [kW]	37.80	23.79	18.40	14.95	11.51	4.58
		T <sub>2N</sub> [Nm]	2,870	3,612	4,190	4,540	5,184	6,177
		P <sub>1NT</sub> [kW]	19.73	17.77	16.41	15.15	13.12	0.00
		Efficiency	0.90	0.90	0.90	0.90	0.89	0.80
30:1	30:1	n <sub>2</sub> [rpm]	50.0	33.0	25.0	16.0	5.0	
		P <sub>1N</sub> [kW]	23.74	19.73	17.62	14.33	7.43	
		T <sub>2N</sub> [Nm]	3,900	4,862	5,790	6,896	10,356	
		P <sub>1NT</sub> [kW]	12.29	11.65	11.03	9.86	0.00	
		Efficiency	0.86	0.86	0.86	0.84	0.73	
40:1	40:1	n <sub>2</sub> [rpm]	75.0	37.0	25.0	18.0	12.0	3.8
		P <sub>1N</sub> [kW]	23.93	18.04	14.66	13.14	10.56	5.58
		T <sub>2N</sub> [Nm]	2,560	3,860	4,761	5,620	6,613	9,942
		P <sub>1NT</sub> [kW]	12.58	11.27	10.56	9.89	8.75	0.00
		Efficiency	0.84	0.84	0.85	0.84	0.82	0.70
53:1	53:1	n <sub>2</sub> [rpm]	57.0	28.0	18.0	14.0	9.4	2.8
		P <sub>1N</sub> [kW]	21.71	13.99	11.19	9.40	6.79	3.09
		T <sub>2N</sub> [Nm]	3,003	3,870	4,701	5,200	5,428	6,985
		P <sub>1NT</sub> [kW]	11.96	10.48	9.65	8.93	7.81	0.00
		Efficiency	0.82	0.82	0.83	0.82	0.79	0.67
62:1	63:1	n <sub>2</sub> [rpm]	48.0	24.0	16.0	12.0	8.1	2.4
		P <sub>1N</sub> [kW]	18.60	11.56	8.81	7.36	5.84	2.99
		T <sub>2N</sub> [Nm]	2,835	3,569	4,081	4,488	5,128	6,946
		P <sub>1NT</sub> [kW]	8.90	7.77	7.28	6.85	6.14	0.00
		Efficiency	0.76	0.77	0.77	0.76	0.73	0.58
83:1	83:1	n <sub>2</sub> [rpm]	36.0	18.0	12.0	9.0	6.0	1.8
		P <sub>1N</sub> [kW]	15.43	9.58	7.31	6.06	4.21	1.61
		T <sub>2N</sub> [Nm]	3,016	3,797	4,343	4,675	4,675	4,675
		P <sub>1NT</sub> [kW]	8.61	7.38	6.80	6.34	5.62	0.00
		Efficiency	0.74	0.75	0.75	0.73	0.70	0.55

	5:1	7.5:1	10:1	13:1	15:1	20:1	26:1	30:1	40:1	53:1	62:1	83:1
T <sub>2max</sub> [Nm]	8500	9800	9277	5396	10500	10000	6790	10500	9800	7500	7000	6800

## Permissible radial force F<sub>r2</sub> and axial force F<sub>a2</sub> on shaft N<sub>2</sub>

n <sub>2</sub> [rpm]	200		125		75		50		30		10	
	F <sub>r</sub> [N]	F <sub>a</sub> [N]	F <sub>r</sub> [N]	F <sub>a</sub> [N]	F <sub>r</sub> [N]	F <sub>a</sub> [N]	F <sub>r</sub> [N]	F <sub>a</sub> [N]	F <sub>r</sub> [N]	F <sub>a</sub> [N]	F <sub>r</sub> [N]	F <sub>a</sub> [N]
< 5000	7500	3750	9300	4650	10300	5150	11500	5750	13500	6750	18000	9000
> 5000	6600	3300	8100	4050	9000	4500	10000	5000	11700	5850	15700	7850

## Inertia moments/mass

Inertia moment J<sub>1</sub> related to the fast-rotating shaft (N<sub>1</sub>)

	Inertia moment [kgcm <sup>2</sup> ]											
	5:1	7.5:1	10:1	13:1	15:1	20:1	26:1	30:1	40:1	53:1	62:1	83:1
J <sub>1</sub>	442.35	316.53	224.31	116.30	241.04	178.87	140.61	222.16	167.51	134.11	186.32	140.89

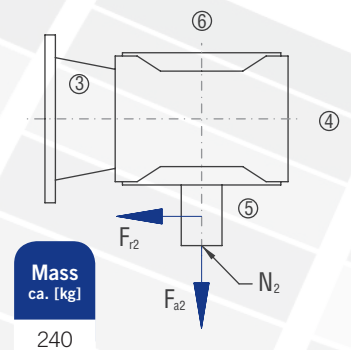

The mass of the gearbox may deviate depending on the flange size, the type and the gear ratio.

# 9.4.13 Type SL 200 – Type S with flange for motor mounting

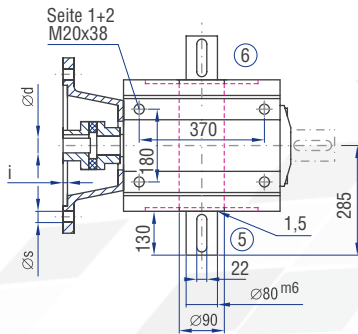
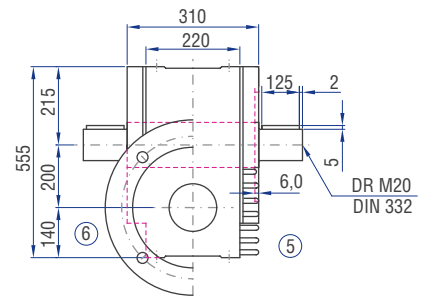
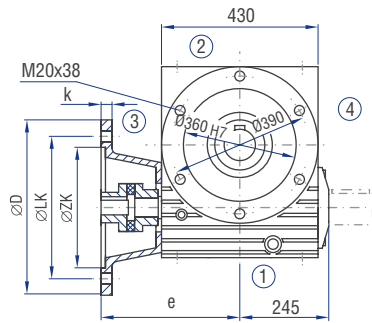
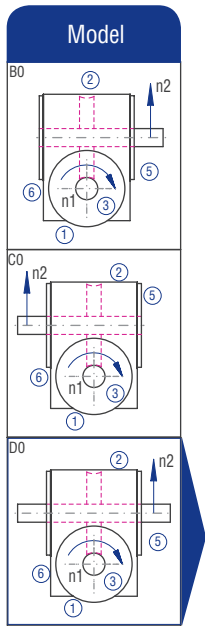

## Implementation VV

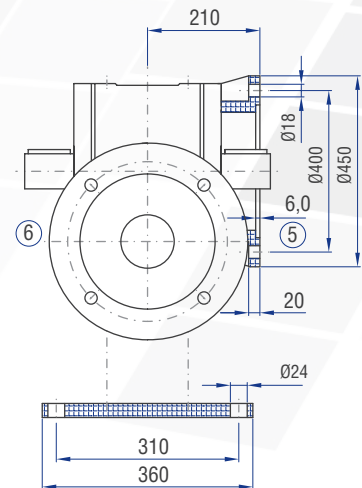
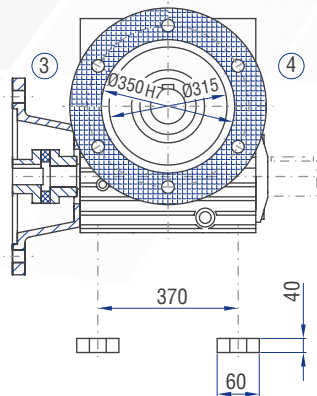
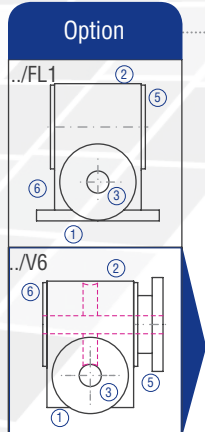
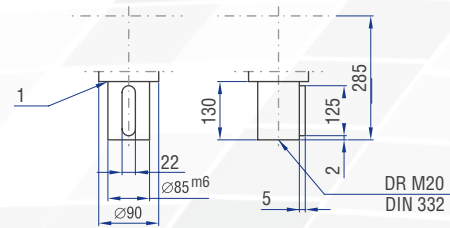

IEC motor	Model	Motor shaft (dxl)	Flange diameter D [mm]	LK [mm]	ZK [mm]	s [mm]	i [mm]	k [mm]	e [mm]
132	B5	38x80	300	265	230	14	5	18	382
160	B5	42x110	350	300	250	18	6	18	415
180	B5	48x110	350	300	250	18	6	18	415
200	B5	55x110	400	350	300	18	6	18	435



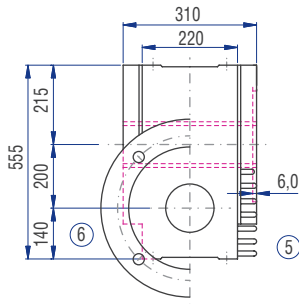
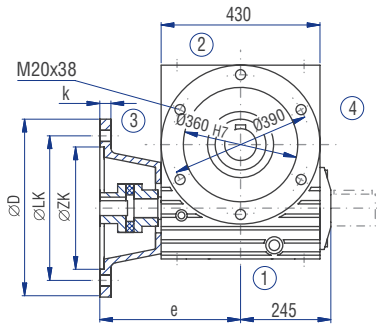

E0N0

E0K5 / E0K6

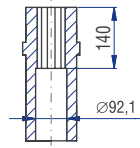
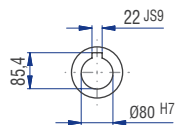
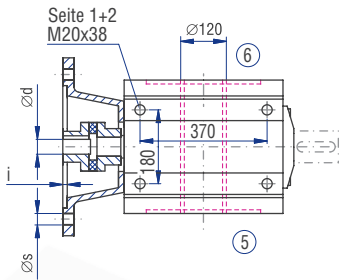

A 10x82x92  
ISO 14

Model

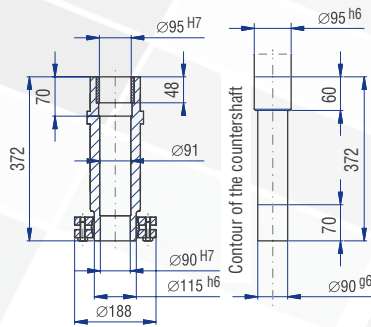
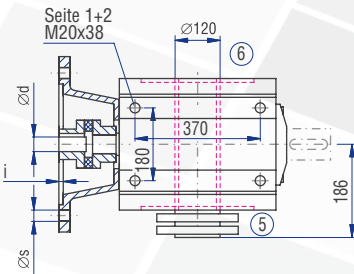
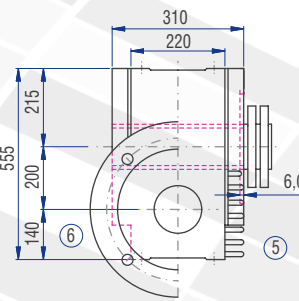
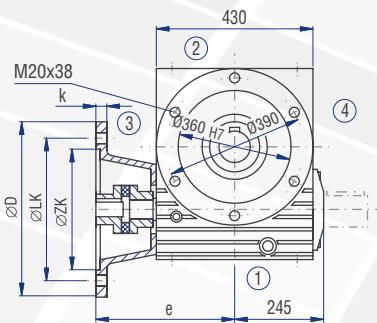
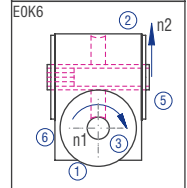
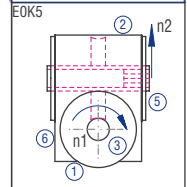
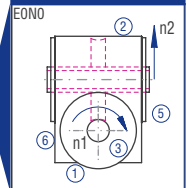

Model

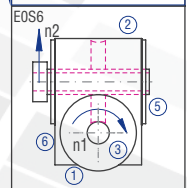
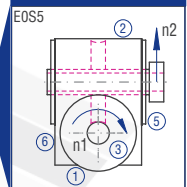

Worm  
gearboxes

## 9.4.14 Type SL 250 – Type S with flange for motor mounting



### Characteristics

Characteristic	Standard	Option
<b>Toothing</b>	Hardened and ground worm shaft / bronze worm gear	See chapter 9.2.1
<b>Gear ratio</b>	7.5:1 to 83:1	
<b>Housing / Flanges</b>	Grey cast iron	
<b>Threaded mounting hole</b>	On gearbox sides 1, 2 and on the flanges	See chapter 9.2.3
<b>Shaft</b>	Material 1 C45, shaft ends greased Fit with ISO j6 tolerance with parallel keyway: according to DIN 6885 Sheet 1	See chapter 4.6.2
<b>Hollow shaft</b>	Material: GGG grey cast iron; shafts greased Fit with ISO H7 tolerance with parallel keyway: according to DIN 6885 Sheet 1	See chapter 4.6.3
<b>Radial shaft seal ring</b>	NBR, form A	See chapter 4.8
<b>Ambient temperature</b>	-10°C to +90°C. The values of the performance tables are valid for 20°C	See chapter 4.9.3
<b>Circumferential backlash</b>	< 30 arcmin	See chapter 9.2.10
<b>Protection class</b>	IP 54	See chapter 4.5
<b>Corrosion protection</b>	Prime coat; layer thickness > 40 µm	See chapter 4.4.1
<b>Bearing life L10h</b>	more than 15,000h	See chapter 4.9.1
<b>Oil change intervals</b>	Not required if the oil temperature is kept below 90°C. The lifetime of the bearings can be increased by the factor 1.5 if the oil is changed after the first 500 service hours and then every 5000 service hours.	See chapter 9.2.8
<b>Lubricants</b>	Synthetic lubricants	See chapter 9.2.8
<b>Flange</b>	Suited for the mounting of IEC motors, models IM B5 and B14	
<b>Coupling</b>	Three-piece claw coupling	

## Performance data

i	i ist		n <sub>1</sub> [rpm]				
			1500	1000	750	500	150
7.5:1	31:4	n <sub>2</sub> [rpm]	200.0	133.0	100.0	66.0	20.0
		P <sub>1N</sub> [kW]	140.64	111.12	90.87	68.37	29.86
		T <sub>2N</sub> [Nm]	6,514	7,720	9,418	9,500	13,260
		P <sub>1NT</sub> [kW]	78.13	69.45	60.58	52.59	0.00
		Efficiency	0.97	0.97	0.97	0.97	0.93
10:1	40:4	n <sub>2</sub> [rpm]	150.0	100.0	75.0	50.0	15.0
		P <sub>1N</sub> [kW]	118.29	89.06	72.81	54.79	54.79
		T <sub>2N</sub> [Nm]	7,230	8,165	8,900	10,047	10,047
		P <sub>1NT</sub> [kW]	73.93	68.51	60.67	49.81	0.00
		Efficiency	0.96	0.96	0.96	0.96	0.96
13:1	52:4	n <sub>2</sub> [rpm]	115.0	76.0	57.0	38.0	11.0
		P <sub>1N</sub> [kW]	93.66	69.15	53.77	38.02	13.65
		T <sub>2N</sub> [Nm]	7,485	9,400	8,709	9,140	10,360
		P <sub>1NT</sub> [kW]	66.90	62.86	53.77	47.52	0.00
		Efficiency	0.96	0.96	0.96	0.95	0.90
15:1	31:2	n <sub>2</sub> [rpm]	100.0	66.0	50.0	33.0	10.0
		P <sub>1N</sub> [kW]	74.97	59.15	48.35	36.78	15.39
		T <sub>2N</sub> [Nm]	6,730	7,965	8,680	9,800	12,790
		P <sub>1NT</sub> [kW]	41.65	36.97	32.23	26.27	0.00
		Efficiency	0.94	0.94	0.94	0.93	0.87
20:1	40:2	n <sub>2</sub> [rpm]	75.0	50.0	37.0	25.0	7.5
		P <sub>1N</sub> [kW]	62.89	47.35	38.71	29.46	12.68
		T <sub>2N</sub> [Nm]	7,447	9,410	9,168	10,352	13,720
		P <sub>1NT</sub> [kW]	41.92	36.42	29.78	26.78	0.00
		Efficiency	0.93	0.93	0.93	0.92	0.85

i	i ist		n <sub>1</sub> [rpm]				
			1500	1000	750	500	150
26:1	52:2	n <sub>2</sub> [rpm]	57.0	38.0	28.0	19.0	5.8
		P <sub>1N</sub> [kW]	50.28	37.84	30.92	23.54	9.92
		T <sub>2N</sub> [Nm]	7,805	8,810	9,600	10,844	13,720
		P <sub>1NT</sub> [kW]	36.68	34.40	30.92	29.43	0.00
		Efficiency	0.92	0.92	0.92	0.91	0.82
30:1	31:1	n <sub>2</sub> [rpm]	50.0	33.0	25.0	16.0	5.0
		P <sub>1N</sub> [kW]	40.69	31.89	26.06	19.84	8.65
		T <sub>2N</sub> [Nm]	6,840	8,040	8,760	9,891	12,727
		P <sub>1NT</sub> [kW]	20.35	19.93	16.29	14.17	0.00
		Efficiency	0.88	0.88	0.88	0.87	0.77
40:1	40:1	n <sub>2</sub> [rpm]	37.0	25.0	18.0	12.0	3.8
		P <sub>1N</sub> [kW]	33.90	25.52	20.87	16.08	7.29
		T <sub>2N</sub> [Nm]	7,410	9,480	9,250	10,445	13,720
		P <sub>1NT</sub> [kW]	24.21	23.20	18.98	17.87	0.00
		Efficiency	0.87	0.87	0.87	0.85	0.74
53:1	52:1	n <sub>2</sub> [rpm]	28.0	18.0	14.0	9.4	2.8
		P <sub>1N</sub> [kW]	27.44	20.64	16.88	13.01	5.81
		T <sub>2N</sub> [Nm]	7,870	8,881	9,685	10,935	13,720
		P <sub>1NT</sub> [kW]	18.29	15.88	16.88	13.01	0.00
		Efficiency	0.85	0.85	0.85	0.83	0.70
62:1	61:1	n <sub>2</sub> [rpm]	24.0	16.0	12.0	8.1	2.4
		P <sub>1N</sub> [kW]	21.87	17.23	14.09	10.88	5.14
		T <sub>2N</sub> [Nm]	6,819	8,060	8,787	9,918	12,581
		P <sub>1NT</sub> [kW]	14.58	13.25	14.09	10.88	0.00
		Efficiency	0.79	0.79	0.79	0.77	0.62
83:1	83:1	n <sub>2</sub> [rpm]	18.0	12.0	9.0	6.0	1.8
		P <sub>1N</sub> [kW]	18.60	14.18	11.25	7.80	2.94
		T <sub>2N</sub> [Nm]	7,765	8,770	9,155	9,155	9,155
		P <sub>1NT</sub> [kW]	14.31	14.18	11.25	9.75	0.00
		Efficiency	0.79	0.78	0.77	0.74	0.59

	7.5:1	10:1	13:1	15:1	20:1	26:1	30:1	40:1	53:1	62:1	83:1
T <sub>2max</sub> [Nm]	13720	13720	10460	13720	13720	13720	13720	13720	13720	13720	13720

## Permissible radial force F<sub>r2</sub> and axial force F<sub>a2</sub> on shaft N<sub>2</sub>

n <sub>2</sub> [rpm]	200		125		75		50		30		10	
	F <sub>r</sub> [N]	F <sub>a</sub> [N]	F <sub>r</sub> [N]	F <sub>a</sub> [N]	F <sub>r</sub> [N]	F <sub>a</sub> [N]	F <sub>r</sub> [N]	F <sub>a</sub> [N]	F <sub>r</sub> [N]	F <sub>a</sub> [N]	F <sub>r</sub> [N]	F <sub>a</sub> [N]
T <sub>2</sub> [Nm]	u.r.	u.r.	u.r.	u.r.	u.r.	u.r.	u.r.	u.r.	u.r.	u.r.	u.r.	u.r.

u.r. – upon request

## Inertia moments/mass

Inertia moment J<sub>1</sub> related to the fast-rotating shaft (N<sub>1</sub>)

J <sub>1</sub>	Inertia moment [kgcm <sup>2</sup> ]										
	7.5:1	10:1	13:1	15:1	20:1	26:1	30:1	40:1	53:1	62:1	83:1
J <sub>1</sub>	0.00	0.00	0.00	0.00	0.00	0.00	0.00	0.00	0.00	0.00	0.00

Mass ca. [kg]
520

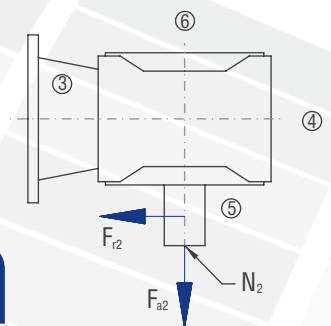

The mass of the gearbox may deviate depending on the flange size, the type and the gear ratio.

# 9.4.14 Type SL 250 – Type S with flange for motor mounting

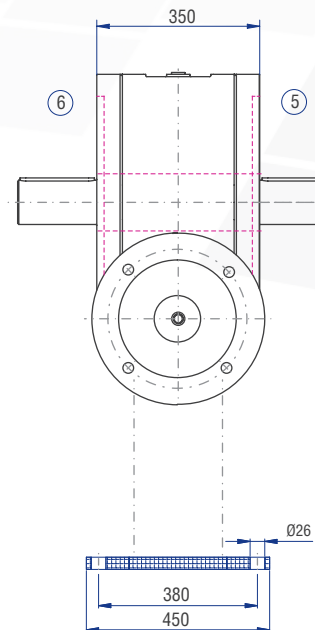
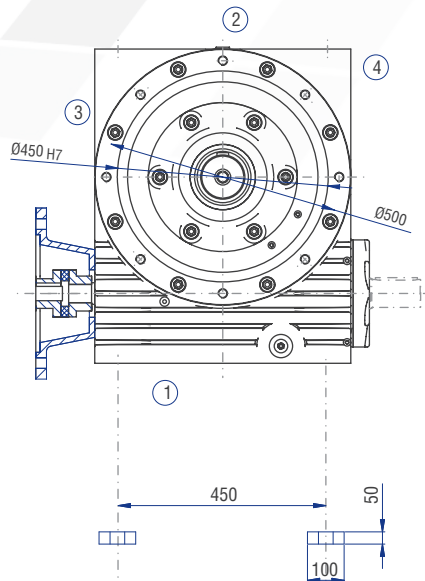
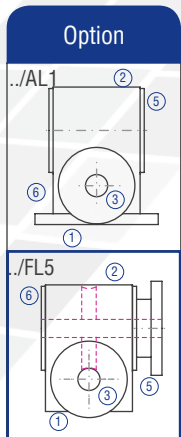
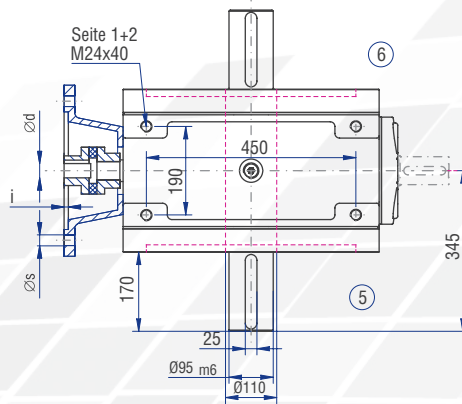
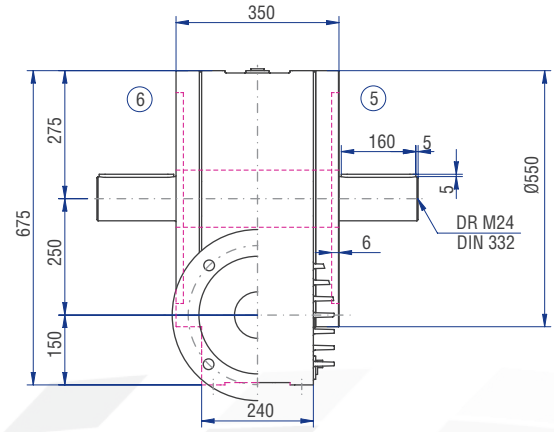
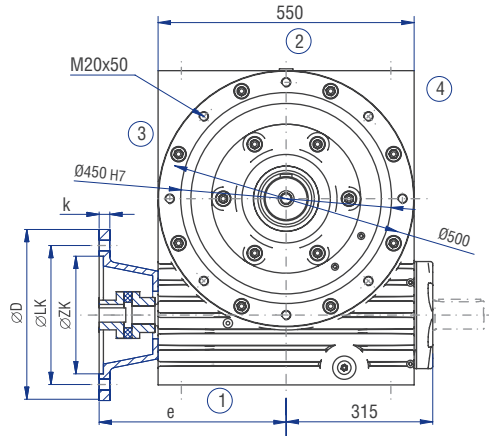
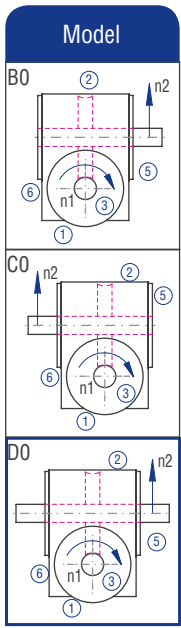

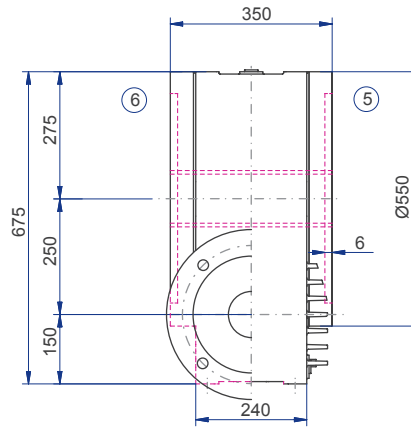
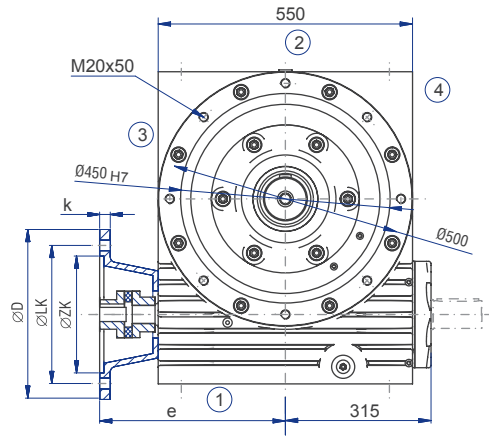

E0N0

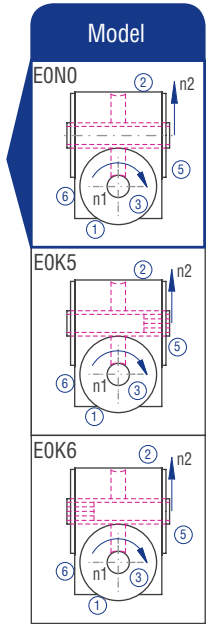
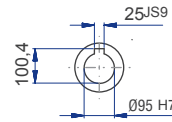
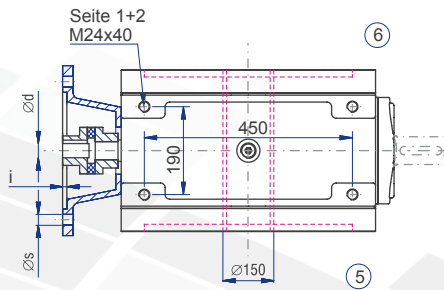

Worm  
gearboxes

IEC motor	Model	Motor shaft (dxl)	Flange diameter D [mm]	LK [mm]	ZK [mm]	s [mm]	i [mm]	k [mm]	e [mm]
160	B5	42x110	350	300	250	18	6	18	520
180	B5	48x110	350	300	250	18	6	18	520
200	B5	55x110	400	350	300	18	6	18	520
225	B5	60x140	450	400	350	18	6	18	545